

An Advisory Committee Statement (ACS)

National Advisory Committee on Immunization (NACI)

Recommendations on the use of conjugate pneumococcal vaccine – 15 valent (PNEU-C-15) and 20 valent (PNEU-C-20) in adults: Economic evidence supplementary appendix

PROTECTING AND EMPOWERING CANADIANS TO IMPROVE THEIR HEALTH



Public Health
Agency of Canada

Agence de la santé
publique du Canada

Canada

**TO PROMOTE AND PROTECT THE HEALTH OF CANADIANS THROUGH LEADERSHIP,
PARTNERSHIP, INNOVATION AND ACTION IN PUBLIC HEALTH.**

— Public Health Agency of Canada

Également disponible en français sous le titre :

Recommandations sur l'utilisation du vaccin conjugué 15-valent (PNEU-C-15) contre le pneumocoque et 20-valent (PNEU-C-20) contre le pneumocoque chez les adultes : Annexe de données économiques supplémentaires

To obtain additional information, please contact:

Public Health Agency of Canada
Address Locator 0900C2
Ottawa, ON K1A 0K9
Tel.: 613-957-2991
Toll free: 1-866-225-0709
Fax: 613-941-5366
TTY: 1-800-465-7735
E-mail: publications-publications@hc-sc.gc.ca

© His Majesty the King in Right of Canada, as represented by the Minister of Health, 2023

Publication date: February 2023

This publication may be reproduced for personal or internal use only without permission provided the source is fully acknowledged.

Cat.: HP5-154/2023E-PDF
ISBN: 978-0-660-47233-1
Pub.: 220714

Preamble

The National Advisory Committee on Immunization (NACI) is an External Advisory Body that provides the Public Health Agency of Canada (PHAC) with independent, ongoing and timely medical, scientific, and public health advice in response to questions from PHAC relating to immunization.

In addition to burden of disease and vaccine characteristics, PHAC has expanded the mandate of NACI to include the systematic consideration of programmatic factors in developing evidence based recommendations to facilitate timely decision-making for publicly funded vaccine programs at provincial and territorial levels.

The additional factors to be systematically considered by NACI include: economics, ethics, equity, feasibility, and acceptability. Not all NACI statements will require in-depth analyses of all programmatic factors. While systematic consideration of programmatic factors will be conducted using evidence-informed tools to identify distinct issues that could impact decision-making for recommendation development, only distinct issues identified as being specific to the vaccine or vaccine-preventable disease will be included.

This statement contains NACI's independent advice and recommendations, which are based upon the best current available scientific knowledge. This document is being disseminated for information purposes. People administering the vaccine should also be aware of the contents of the relevant product monograph. Recommendations for use and other information set out herein may differ from that set out in the product monographs of the Canadian manufacturers of the vaccines. Manufacturer(s) have sought approval of the vaccines and provided evidence as to its safety and efficacy only when it is used in accordance with the product monographs. NACI members and liaison members conduct themselves within the context of PHAC's Policy on Conflict of Interest, including yearly declaration of potential conflict of interest.

A systematic review, de novo model-based economic evaluation, and a multi-model comparison were used as economic evidence to support decision-making for the use of 15-valent (PNEU-C-15) and 20-valent (PNEU-C-20) conjugate vaccines. Each component is described below.

Table of Contents

| | |
|--|-----------|
| I. Systematic Review | 5 |
| I.1 Description of Included Studies | 5 |
| I.2 Results of Age-Based Strategies | 6 |
| I.3 Results of Risk-Based Strategies | 8 |
| I.4 Results of Combined Age- and Risk-Based Strategies | 9 |
| I.5 Generalizability | 9 |
| I.6 Influential Parameters and Assumptions | 10 |
| I.7 Conclusions | 10 |
| II. Cost-Utility Analysis | 11 |
| II.1 Economic Model Description | 11 |
| II.2 Model Parameters | 12 |
| II.3 Base Case | 20 |
| II.4 Sensitivity Analysis | 26 |
| II.5 Scenario Analyses | 29 |
| II.6 Study limitations | 32 |
| II.7 Conclusions | 33 |
| III. Multi-Model Comparison | 34 |
| III.1 Approach | 34 |
| III.2 Multi-Model Comparison Results | 35 |
| III.3 Conclusions | 35 |
| List of Abbreviations | 36 |
| References | 38 |

I. SYSTEMATIC REVIEW

A systematic review of the cost-effectiveness of PNEU-C-15 and PNEU-C-20 vaccines for preventing pneumococcal disease (PD) was conducted. The review included economic evaluations conducted in adults aged 18 or older, comparing currently used vaccines to prevent pneumococcal disease to PNEU-C-15 or PNEU-C-20. The components of the research question are:

- **Population:** Adults aged 18 years or older
- **Intervention:** PNEU-C-15 or PNEU-C-20 (alone or in series with other pneumococcal vaccines)
- **Comparator:** Current vaccines for pneumococcal disease (PNEU-C-7, PNEU-C-10, PNEU-C-13, PNEU-P-23 (23-valent polysaccharide))
- **Outcomes:** Measures of cost-effectiveness (incremental cost per quality-adjusted life year, incremental cost per disability-adjusted life year, cost per life year, etc.)

A systematic literature search of Embase, International Pharmaceutical Abstracts, Ovid Medline, EBM Reviews, and Econlit was conducted for January 1, 2018, to September 30, 2021. Language of publication was restricted to English or French. Keywords used included: pneumococcal vaccine, conjugate vaccine, pneumococcal infection, PCV15, PCV20, economic evaluation, economic impact, and financial effect. The search strategy was developed in consultation with and validated by a librarian. A search of grey literature was also conducted, guided by recommendations put forth by the Canadian Agency for Drugs and Technologies in Health (CADTH) in their Grey Matters tool, which is a checklist of grey literature sources including both Canadian and international health technology assessment agencies¹. Titles and abstracts of retrieved references were screened using DistillerSR systematic literature review software² by two reviewers. Inclusion and exclusion criteria were discussed prior to screening to ensure criteria would be applied consistently, and any discrepancies were resolved through discussion. The full texts of references that were eligible for inclusion after title and abstract screening were retrieved and assessed by the same two reviewers to determine final inclusion/exclusion. A standardized data extraction tool was used to record study characteristics, methods, and findings of included studies. ICERs are presented in 2021 US dollars and were inflated using the Health Care component of Personal Consumption Expenditures where necessary³. The Joanna Briggs Institute (JBI) Critical Appraisal Checklist for Economic Evaluations⁴ was used to assess the overall quality of included studies. The applicability or transferability of included studies was assessed using Heyland's Generalizability Criteria⁵. No studies were excluded on the basis of these appraisals.

I.1 Description of Included Studies

Four model-based cost-utility analyses were identified, all of which were conducted in the United States. Only one study was published in the peer-reviewed literature at the time of the search⁶, with the remaining studies identified in a search of the grey literature. Results for three of the economic evaluations were included in a single report to the Advisory Committee on Immunization Practices (ACIP)⁷. To distinguish between these studies, the three economic evaluations from this single report are referred to by the names of the authors of the individual studies⁸⁻¹⁰. A version of one of the studies included in the ACIP report was also described in greater detail in a separate report¹¹. Two of the four included studies were industry sponsored^{8, 9}. Two studies used a health system perspective^{6, 9} and two used a societal perspective^{8, 10}. All studies used a 3% discount rate for costs and outcomes, as recommended in the US. Cost-effectiveness outcomes were

reported as ICERs, presented as the incremental cost per QALY gained. All studies used a lifetime time horizon.

Two studies used Markov models that followed a single age cohort over time^{6, 10} and the other two used multi-cohort Markov models that followed a population consisting of multiple age cohorts over time^{8, 9}. Although the model structures varied, all used a similar approach to model the risk of PD, generally conceptualized as invasive pneumococcal disease (IPD) or non-bacteremic pneumococcal pneumonia (NBPP) and the potential for long-term sequelae following IPD. Risk of PD was dependent on age, vaccination status, and for some models, presence of immunocompromising conditions (IC) or chronic medical conditions (CMC). None of the models used were dynamic but some did evaluate indirect effects by assuming a reduction in vaccine-type PD incidence over time due to potential use of PNEU-C-15 or PNEU-C-20 in pediatric populations^{9, 10}.

The model-based evaluations compared outcomes, including costs and QALYs, for vaccination strategies using PNEU-C-15 or PNEU-C-20 to current US recommendations. At the time the studies were conducted, the US pneumococcal vaccination guidance for adults aged 19 years or older included the following age- and risk-based recommendations: PNEU-P-23 plus optional PNEU-C-13 under shared clinical decision-making for adults aged 65 years or older; PNEU-P-23 at diagnosis of chronic medical conditions (CMC) if under age 65 years; and PNEU-C-13 in series with PNEU-P-23 at diagnosis of IC if under age 65 years¹². Different age-, risk-, or combined age- and risk-based vaccination strategies were evaluated, which are discussed in turn below. Results are presented for both the health system and societal perspectives, with the perspective used noted in the tables.

1.2 Results of Age-Based Strategies

All four model-based economic evaluations examined the cost-effectiveness of age-based strategies, consisting of different approaches for the use of PNEU-C-15 or PNEU-C-20 either alone or in series with PNEU-P-23 in the population aged 50 or 65 years and older ([Table 1](#)).

The use of PNEU-C-15 alone in the population aged 65 years was evaluated in a single study and was found to have an ICER ranging from \$250,434 to 479,494 per QALY gained compared to the current vaccine recommendations in this age group⁶. The ICER was higher when indirect effects of a potential pediatric vaccination program for reducing adult PD were included. There was variability across the three studies that reported results for use of PNEU-C-15 in series with PNEU-P-23 at age 65 years. One study estimated that use of PNEU-C-15 plus PNEU-P-23 would result in lower costs and improved health outcomes compared to current recommendations (i.e., was the dominant strategy)¹⁰. The two other studies estimated ICERs ranging from \$237,000-611,169 per QALY gained^{6, 8}, suggesting that this strategy was unlikely to be considered cost-effective under commonly used thresholds.

Three studies evaluated the use of PNEU-C-20 alone at age 50 years compared to the current age-based recommendations. One study reported variable estimates of potential value, depending on assumptions, ranging from PNEU-C-20 dominating current recommendations when indirect effects were included, to use of PNEU-C-20 leading to lower costs and reduced health outcomes when indirect effects were ignored¹⁰. A second study estimated ICERs ranging from \$174,000-514,000 per QALY gained⁸ and the third study reported an ICER of \$18,000 per QALY gained⁹.

Four studies evaluated the use of PNEU-C-20 alone at age 65 years compared to the current age-based recommendations. Two studies reported PNEU-C-20 to be the dominant strategy, resulting in lower costs and improved outcomes compared to current recommendations^{9, 10}. In one study that included four scenario analyses, ICERs ranged from dominant to \$39,000 per QALY gained⁸. In another study, the ICER estimates ranged from \$187,761-410,900 per QALY gained⁶.

The single study to evaluate PNEU-C-20 in series with PNEU-P-23 at age 65 years showed the strategy was unlikely to be cost-effective, with ICERs ranging from \$488,716-704,702 per QALY gained⁶.

Table 1. Incremental cost-effectiveness ratios for age-based vaccination strategies using PNEU-C-15 or PNEU-C-20 compared to current recommendations.

| Vaccine | Strategy | Age | Indirect effects included | ICER (\$/QALY) | | | |
|-----------|--------------------------|-----|---------------------------|---|--|---|---|
| | | | | Smith et al. ⁶ , health system perspective | Stoecker et al. ¹⁰ , societal perspective | Owusu-Edusei et al. ^{a,8} , societal perspective | Weycker et al. ⁹ , health system perspective |
| PNEU-C-15 | Alone | 65 | No | 250,434 ^b | -- | -- | -- |
| | | | Yes | 479,492 ^b | -- | -- | -- |
| PNEU-C-15 | In series with PNEU-P-23 | 65 | No | 490,302 ^b | Dominant | 237,000-282,000 | -- |
| | | | Yes | 611,169 ^b | Dominant | -- | -- |
| PNEU-C-20 | Alone | 50 | No | -- | Lower costs and lower QALYs (5,300,000) | 174,000-514,000 | 18,000 |
| | | | Yes | -- | Dominant | -- | -- |
| PNEU-C-20 | Alone | 65 | No | 187,761 | Dominant | Dominant to 39,000 | Dominant |
| | | | Yes | 410,900 | Dominant | -- | -- |
| PNEU-C-20 | In series with PNEU-P-23 | 65 | No | 488,716 | -- | -- | -- |
| | | | Yes | 704,702 | -- | -- | -- |

^a Base case included four different scenarios

^b Analysis assumes PNEU-C-13 and PNEU-C-20 are ineffective against PD caused by serotype 3; PNEU-C-15 was dominated in an analysis assuming equal serotype 3 vaccine effectiveness for PNEU-C-15 and PNEU-C-13/PNEU-C-20.

I.3 Results of Risk-Based Strategies

Three studies evaluated the cost-effectiveness of risk-based strategies in people aged 19 to 49 or 19-64 years with IC or CMC, population groups for whom different pneumococcal vaccination recommendations apply in the US, where the studies were conducted (Table 2).

The two studies that evaluated risk-based use of PNEU-C-15 in series with PNEU-P-23 in the population aged 19-64 years found this strategy unlikely to be cost-effective under commonly used thresholds, with ICERs ranging from \$250,000-656,000 per QALY gained^{8, 10}.

There was variability across the three studies that evaluated the use of PNEU-C-20 alone for the population aged 19-49 years. In scenario analyses, one study reported that the use of PNEU-C-20 would range from dominating current recommendations to an ICER of \$25,000 per QALY gained⁸. The other two studies reported a range from \$94,000-\$483,000 per QALY gained^{9, 10}.

Risk-based use of PNEU-C-20 in the population aged 19-64 years also produced variable results across studies, with one study suggesting that the strategy could be cost-effective or dominate current recommendations⁹, and the other two studies estimating ICERs ranging from \$58,999-\$292,000 per QALY gained^{8, 10}. Overall, risk-based use of PNEU-C-20 was estimated to result in lower ICERs when the strategy was used in the population aged 19-64 years compared to its use in the population aged 19-49 years.

Table 2. Incremental cost-effectiveness ratios for risk-based vaccination strategies using PNEU-C-15 or PNEU-C-20

| Vaccine | Strategy | Age | Indirect effects included | ICER (\$/QALY) | | |
|-----------|--------------------------|-------|---------------------------|--|---|---|
| | | | | Stoecker et al. ¹⁰ , societal perspective | Owusu-Edusei et al. ^{a,8} , societal perspective | Weycker et al. ⁹ , health system perspective |
| PNEU-C-15 | In series with PNEU-P-23 | 19-64 | No | 656,000 ^b | 250,000-312,000 | -- |
| PNEU-C-20 | Alone | 19-49 | No | 483,000 ^c | 94,000-273,000 | Dominant |
| | | | Yes | -- | -- | 25,000 |
| PNEU-C-20 | Alone | 19-64 | No | 292,000 ^d | 58,000-183,000 | Dominant |
| | | | Yes | -- | -- | 11,000 |

Unless otherwise specified, the comparator is current recommendations for people with immunocompromising or chronic medical conditions.

^a Range represents results from four different scenarios.

^b Comparator is PNEU-C-15 in series with PNEU-P-23 at age 65 years; ICER represents the incremental effect of program expansion to include vaccination of the population aged 19-64 years upon diagnosis of CMC/IC.

^c Comparator is PNEU-C-20 at age 50 years; ICER represents the incremental effect of program expansion to include vaccination of the population aged 19-49 years upon diagnosis of CMC/IC.

^d Comparator is PNEU-C-20 at age 65 years; ICER represents the incremental effect of program expansion to include vaccination of the population aged 19-64 years upon diagnosis of CMC/IC.

I.4 Results of Combined Age- and Risk-Based Strategies

Two studies evaluated combined age- and risk-based strategies ([Table 3](#)). Overall, evaluations that combined age- and risk-based strategies tended to result in more favourable ICER estimates compared to risk-based only strategies.

PNEU-C-15 use in series with PNEU-P-23 for people with CMC or IC aged 19-64 years and at age 65 years for the general population was not likely to be cost-effective under commonly used thresholds in the single study that evaluated this strategy (ICER of \$338,000 per QALY gained)¹⁰.

The use of PNEU-C-20 alone for people aged 19-49 years with CMC or IC and the general population at age 50 years resulted in estimates ranging from dominant to \$11,000 per QALY gained^{9, 10}. The use of PNEU-C-20 alone for people aged 19-64 years with CMC or IC and the general population at age 65 years was estimated to dominate current recommendations in both studies^{9, 10}. This finding was consistent with the age-only and risk-based only comparisons, where the interventions appeared more cost-effective at age 65 years compared to at 50 years.

Table 3. Incremental cost-effectiveness ratios for combined age-and risk-based vaccination strategies using PNEU-C-15 or PNEU-C-20 compared to current recommendations.

| Vaccine | Strategy | Age | Indirect effects included | ICER (\$/QALY) | |
|-----------|--------------------------|---|---------------------------|--|---|
| | | | | Stoecker et al. ¹⁰ , societal perspective | Weycker et al. ⁹ , health system perspective |
| PNEU-C-15 | In series with PNEU-P-23 | 19-64 for people with CMC/IC; 65 for general population | No | 338,000 | -- |
| PNEU-C-20 | Alone | 19-49 for people with CMC/IC; 50 for general population | No | Dominant | 11,000 |
| PNEU-C-20 | Alone | 19-64 for people with CMC/IC; 65 for general population | No | Dominant | Dominant |

I.5 Generalizability

Given that all of the studies were conducted in the US, the transferability of the cost-effectiveness estimates was assessed. The clinical generalizability, analysis type, costing method, outcome measure method, and use of a preference-based measure instrument to obtain utility values were aligned with the NACI guidelines for the conduct of economic evaluations in the Canadian setting¹³. The discount rate (3%) was higher than the recommended discount rate of 1.5%. The US vaccination recommendations at the time of the analyses differed from Canadian pneumococcal vaccination recommendations, such that the comparator used in the included analyses may not reflect the Canadian context. For instance, in the US, PNEU-P-23 plus optional PNEU-C-13 under shared clinical decision-making was recommended for adults aged 65 years

or older, while in Canada, population-level recommendations were for PNEU-P-23 for this age group.

I.6 Influential Parameters and Assumptions

Model parameters that were reported to influence the estimated cost-effectiveness included: overall effectiveness of the conjugate vaccines; effectiveness of the conjugate vaccines against serotype 3 disease; waning of vaccine effectiveness; incidence of pCAP, and vaccine price. The assumption of declines in vaccine-type disease in the adult population associated with a putative infant vaccination program generally resulted in higher ICERs than scenarios that did not consider these potential indirect effects.

ICER estimates from Smith et al.⁶ tended to be higher than in the other models, with results generally less favourable toward to use of PNEU-C-15 or PNEU-C-20 relative to current vaccine recommendations. Although reasons for this difference are uncertain, the Smith et al. study differed from the others by not modelling people with IC. It also used less recent data for vaccine serotype coverage and PD incidence⁷. This model, along with that of Weycker et al.⁹ used the health system perspective; the use of a narrower perspective (compared to the societal one) that does not account for the full range of benefits associated with vaccination programs may also have contributed to less favourable cost-effectiveness estimates.

I.7 Conclusions

A review of the peer-reviewed and grey literature identified four cost-utility studies of PNEU-C-15 and PNEU-C-20 compared to current vaccination recommendations. The studies generally found that PNEU-C-20 use in older adults was associated with increased QALYs, with lower ICERs when the vaccine was used in adults aged 65 years and older compared to programs in adults aged 50 years and older. ICER estimates for PNEU-C-15 use in series with PNEU-P-23 at age 65 years showed variability across studies. The estimated impact of adding risk-based programs for younger adults with IC/CMC to an age-based strategy depended on the vaccine product, with more favourable cost-effectiveness estimates for PNEU-C-20 than for PNEU-C-15 in series PNEU-P-23.

II. COST-UTILITY ANALYSIS

II.1 Economic Model Description

A cost-utility model was developed to evaluate the cost-effectiveness of PNEU-C-15 and PNEU-C-20 vaccines in the Canadian population. The model compared the health and economic outcomes of different vaccination strategies. Summaries of the methods and results are provided below.

The economic analysis incorporated the following considerations: recommended age at vaccination and whether PNEU-C-15 or PNEU-C-20 should be used alone or in series with PNEU-P-23. Given higher rates of PD in circumpolar regions of Canada, separate analyses were conducted for the Northern Territories (Northwest Territories, Yukon, and Nunavut) and the provinces, referred to as “North” and “Rest of Canada” (ROC), respectively. Due to data limitations, the model only evaluated age-based vaccination strategies and did not separately model risk in population groups known to experience higher risk of PD, including people with immunocompromising conditions and chronic medical conditions.

The model followed a single cohort of people aged 50, 65, or 75 years without a history of previous pneumococcal vaccination over their lifetime. The age at model entry was varied to evaluate different possible age recommendations for vaccination. The current Canadian population-level recommendation of PNEU-P-23 use for older adults was compared to PNEU-C-15 or PNEU-C-20 alone or in series with PNEU-P-23. When used in series, the conjugate vaccine was assumed to be given first, followed by PNEU-P-23 one year later. Vaccine was assumed to be administered on model entry.

People did not have PD on model entry but could develop invasive pneumococcal disease (IPD) or pneumococcal community-acquired pneumonia (pCAP) over their lifetimes ([Figure 1](#)). pCAP could be treated outside of the hospital (outpatient) or require hospitalization (inpatient). There was a risk of death associated with PD and mortality from other causes was also modelled¹⁴. People recovering from IPD (all assumed to require hospitalization) could experience long-term consequences associated with their infection (neurologic or auditory sequelae). Vaccination was assumed to reduce the risk of pneumococcal disease due to serotypes included in the vaccine. The cohort model was static and did not incorporate dynamic feedbacks. It used a lifetime time horizon, a discount rate of 1.5% for costs and outcomes, and assessed cost-effectiveness from the health system and societal perspectives. The model was programmed using R 4.0 and the *data.table* package and used the approach described by Krijkamp et al. (2020)¹⁵⁻¹⁷.

Model outcomes included cases of IPD and pCAP, deaths due to PD, life years, quality-adjusted life years (QALYs), and costs. QALYs and costs were used to estimate incremental cost-effectiveness ratios (ICERs). Model estimates were based on 2,000 simulations with parameters drawn from distributions. Conventional probability distributions were used: beta distributions were used for parameters constrained between zero and one, such as probabilities and utilities; Dirichlet distributions were used for multivariate probabilities, such as the proportion of PD cases attributable to serotype groups; gamma and lognormal distributions were used for parameters constrained to positive values, such as costs and rate ratios. Because multiple vaccine products and strategies were evaluated, sequential analyses were conducted, to determine if certain strategies would result in a more efficient use of resources. For a given age group and geographic

region, sequential ICERs were calculated by ordering the strategies by lowest to highest cost and comparing the incremental costs and QALYs gained for a given strategy to the next less costly strategy. In the sequential analysis, strategies could be eliminated because there were other strategies that were projected to result in more QALYs gained at lower costs (i.e., the strategy was dominated) or there was a combination of other strategies that would result in more QALYs gained for lower costs, such that the excluded strategy would never be the optimal intervention, regardless of the cost-effectiveness threshold used (i.e., the strategy was subject to extended dominance).

Figure 1. Overview of health states included in the model and possible transitions between health states

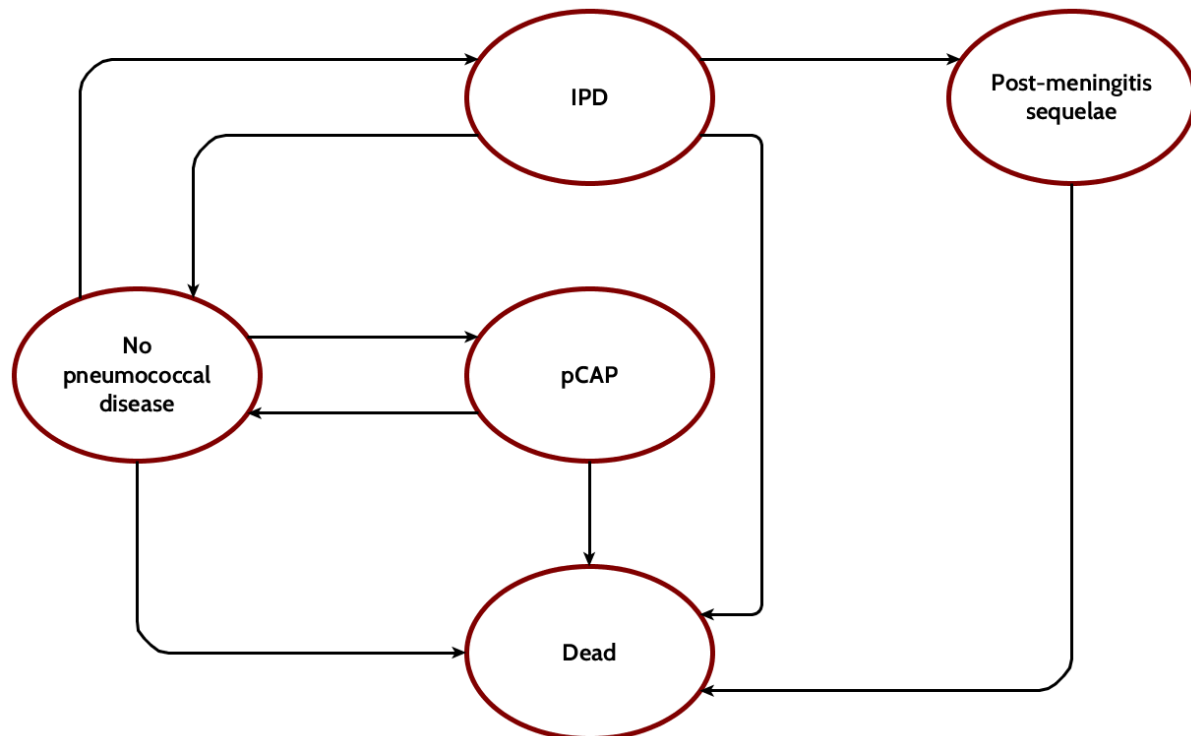

IPD=invasive pneumococcal disease; pCAP=pneumococcal community acquired pneumonia.

II.2 Model Parameters

Model parameters describing PD epidemiology (Table 4), vaccine characteristics (Table 5), costs (Tables 6 and 7), and health utilities (Table 8) were derived from available data and literature, wherever possible, and by assumption otherwise. Canadian data were used preferentially, when available. In the absence of vaccine effectiveness (VE) data for PNEU-C-15 and PNEU-C-20, VE was assumed to be equal to that reported for PNEU-C-13 but extended to cover additional serotypes not included in PNEU-C-13. VE for preventing PD caused by serotype 3 was assumed lower than for other serotypes for the conjugate and polysaccharide vaccines^{11, 18}. Protection was assumed to be more durable for the conjugate vaccines than for PNEU-P-23¹⁰.

Data on age- and region-specific incidence of IPD were obtained from the International Circumpolar Surveillance program and the Canadian Notifiable Disease Surveillance System¹⁹. Incidence of community-acquired pneumonia (CAP) was estimated using records of

hospitalizations with pneumonia from the Discharge Abstract Database in 2018-2019. Data from the Serious Outcomes Surveillance (SOS) Network was used to estimate the proportion of hospitalized CAP cases due to *S. pneumoniae*²⁰. The incidence of outpatient pCAP cases was estimated from studies reporting the proportion of CAP cases that are hospitalized²¹⁻²⁴. The proportion of PD cases attributable to serotypes contained in the vaccines was obtained from Canadian surveillance data^{19, 20}. Estimates of case-fatality^{20, 25} and risk of long-term sequelae²⁶⁻³⁵ were obtained from the literature.

Costs of IPD and hospitalizations with pneumonia were estimated using Resource Intensity Weights obtained from the Discharge Abstract Database (2015-2019)³⁶⁻³⁹ and the cost of a standard hospital stay⁴⁰. Costs of outpatient pneumonia were assumed to comprise either a physician office visit or an emergency department visit. Costs of long-term sequelae were based on costs of auditory or neurologic complications of bacterial meningitis⁴¹. Vaccination costs included administration costs⁴² and vaccine price. The prices of PNEU-P-23 and PNEU-C-13 were based on contract prices communicated in confidence by PHAC Vaccine Supply and Assurance. Prices for PNEU-C-15 and PNEU-C-20 were based on the relative US incremental prices of these vaccines compared to PNEU-C-13⁴³. Based on the US data, the incremental price for PNEU-C-20 was higher than that for PNEU-C-15. For the societal perspective, costs included productivity loss due to illness, caregiver costs, and out-of-pocket medical costs. Productivity loss was estimated using the human capital method.

Age-specific utilities for the Canadian general population were based on EQ-5D-5L index scores of residents from Alberta, Canada⁴⁴. Utilities of IPD, pCAP, and long-term sequelae were derived by applying utility multipliers for each condition⁴⁵⁻⁵⁰ against utility norms for the general population.

Table 4. Epidemiological parameters

| Parameter | Base | Range | Reference | |
|--|--------|-----------------|---|--|
| IPD incidence (per 100,000) | | | | |
| 50-64 years | | | | |
| Northern Canada | 38.97 | 23.10 – 58.93 | CNDSS 2018-2019; ICS 2018-2019 ¹⁹ | |
| Rest of Canada | 14.45 | 13.83 – 15.09 | | |
| 65-74 years | | | | |
| Northern Canada | 71.30 | 34.20 – 121.79 | | |
| Rest of Canada | 20.61 | 19.52 – 21.72 | | |
| 75+ years | | | | |
| Northern Canada | 105.01 | 38.55 – 204.12 | | |
| Rest of Canada | 31.06 | 29.51 – 32.65 | | |
| CAP (inpatient) incidence (per 100,000) | | | | |
| 50-64 years | | | | |
| Northern Canada | 568.81 | 502.43 – 639.22 | DAD 2018-2019 ³⁹ | |
| Rest of Canada | 347.81 | 344.46 – 351.17 | | |

| Parameter | Base | Range | Reference |
|---|---------|-------------------|---|
| 65-74 years | | | |
| Northern Canada | 1777.32 | 1568.36 – 1998.91 | |
| Rest of Canada | 871.48 | 863.81 – 879.20 | |
| 75+ years | | | |
| Northern Canada | 5104.13 | 4555.27 – 5682.02 | |
| Rest of Canada | 2845.89 | 2829.84 – 2861.97 | |
| Proportion of CAP cases attributed to <i>S. pneumoniae</i> (%) | | | |
| 50-64 years | 19.4 | 17.4 – 21.6 | LeBlanc et al 2022 ²⁰ |
| 65-74 years | 13.9 | 12.1 – 15.8 | |
| 75+ years | 9.5 | 8.3 – 10.7 | |
| Odds CAP case managed in outpatient setting | | | |
| 50-64 years | 2.6 | 0.8 – 6.5 | Jokinen et al 1993; Nelson et al 2008; Mathijssen and Ignacio 2022; Averin et al 2022 ²¹⁻²⁴ |
| 65-74 years | 1.2 | 0.5 – 2.5 | |
| 75+ years | 1.0 | 0.4 – 2.1 | |
| Vaccine-type serotype distribution (%) | | | |
| 50-64 years | | | National Microbiology Laboratory 2019 ¹⁹ |
| ST3 | 11.5 | 9.6 – 13.5 | |
| PNEU-C-13/non-ST3 | 21.3 | 18.8 – 23.8 | |
| PNEU-C-15/non-PNEU-C-13 | 12.2 | 10.3 – 14.3 | |
| PNEU-C-20/non-PNEU-C-15 | 19.2 | 16.9 – 21.7 | |
| PNEU-P-23/non-PNEU-C-20 | 15.7 | 13.5 – 18.0 | |
| NVT | 20.1 | 17.7 – 22.6 | |
| 65+ years | | | |
| ST3 | 13.2 | 11.6 – 15.0 | |
| PNEU-C-13/non-ST3 | 16.0 | 14.2 – 17.9 | |
| PNEU-C-15/non-PNEU-C-13 | 15.4 | 13.6 – 17.3 | |
| PNEU-C-20/non-PNEU-C-15 | 13.5 | 11.8 – 15.3 | |
| PNEU-P-23/non-PNEU-C-20 | 10.1 | 8.6 – 11.7 | |
| NVT | 31.7 | 29.3 – 34.1 | |

| Parameter | Base | Range | Reference |
|--|------|-------------|--|
| Proportion of IPD survivors with long-term sequelae (%) | | | |
| Auditory sequelae | 2.1 | 1.8 – 2.5 | Schut et al 2011; Ostergaard et al 2005; Hoogman et al 2007; Brouwer et al 2010; Active Bacterial Core Surveillance System 2019; Wijayasri 2019; Heckenberg et al 2012; Worsoe et al 2010 ^{25,27,29-31,33,34} |
| Neurologic sequelae | 1.9 | 1.6 – 2.2 | |
| Case fatality (%) | | | |
| IPD | | | |
| 50-64 years | 10.9 | 9.9 – 12.0 | Wijayasri 2019 ²⁵ |
| 65+ years | 17.2 | 16.2 – 18.3 | |
| pCAP (inpatient) | | | |
| 50-64 years | 4.8 | 2.9 – 7.1 | LeBlanc et al 2022 ²⁰ |
| 65+ years | 9.9 | 7.7 – 12.3 | |

IPD = invasive pneumococcal disease; CAP = community-acquired pneumonia; pCAP = pneumococcal community-acquired pneumonia; ST3 = serotype 3; NVT = non-vaccine type

Table 5. Vaccine characteristics

| Parameter | Base | Range | Reference |
|--|---|--|---|
| Vaccination coverage (%) | | | |
| 50-64 years | 48.3 | 43.7 – 53.0 | Used same value as 65-74 years |
| 65-74 years | 48.3 | 43.7 – 53.0 | Seasonal Flu Survey 2021 ⁵¹ |
| 75+ years | 65.4 | 59.6 – 71.2 | Seasonal Flu Survey 2021 ⁵¹ |
| PNEU-C effectiveness at age 65 (%) | | | |
| VT-IPD | 60.0 | 34.0 – 76.0 | Assumption based on Farrar et al 2021 and Bonten et al 2015 ^{52, 53} |
| ST3-IPD | 26.0 | 0 – 53.4 | Stoecker 2020 ¹¹ |
| VT-CAP | 45.0 | 14.0 – 65.0 | Assumption based on Childs et al 2021 and Bonten et al 2015 ^{53, 54} |
| ST3-CAP | 15.6 | 0 – 22.7 | Stoecker 2020 ¹¹ |
| PNEU-P-23 effectiveness at age 65 (%) | | | |
| VT-IPD | 47.0 | 32.0 – 63.0 | Djennad et al 2018 ¹⁸ |
| ST3-IPD | 2.0 | 0 – 21.0 | Djennad et al 2018 ¹⁸ |
| VT-CAP | 20.0 | 0 – 40.0 | Lawrence et al 2020 ⁵⁵ |
| ST3-CAP | 2.0 | 0 – 21.0 | Assumption of similar effect used for ST3-IPD |
| Vaccine effectiveness at age 50 | 1.1 x effectiveness at age 65 | | Assumption |
| Vaccine effectiveness at age 75 | 0.9 x effectiveness at age 65 | | Assumption |
| Duration of protection | | | |
| PNEU-C | 15 years: stable for 5 years, linear decline to 0 over 10 years | 12 years: stable for 5 years, linear decline to 0 over 7 years | Stoecker 2020 ¹⁰ |
| PNEU-P-23 | 15 years: linear decline to 0 over 15 years | 7 years: linear decline to 0 over 7 years | |

VT = vaccine-type; ST3 = serotype 3

Table 6. Direct cost parameters

| Parameter | Base | Range | Reference | |
|--|----------|----------------------|--|--|
| Cost of vaccine administration | 16.77 | 12.58 – 20.96 | NACI 2018 ⁴² | |
| Cost per IPD case | | | | |
| 50-64 years | 29,146 | 27,363 – 30,984 | DAD 2015-2019 ³⁶⁻³⁹ | |
| 65-74 years | 28,955 | 26,727 – 31,271 | | |
| 75+ years | 21,501 | 20,001 – 23,054 | | |
| Cost per inpatient CAP case | | | | |
| 50-64 years | | | | |
| Northern Canada | 11,725 | 10,575 – 12,933 | DAD 2015-2019 ³⁶⁻³⁹ | |
| ROC | 9,813 | 9,730 – 9,897 | | |
| 65-74 years | | | | |
| Northern Canada | 10,297 | 9,466 – 11,163 | | |
| ROC | 9,992 | 9,910 – 10,074 | | |
| 75+ years | | | | |
| Northern Canada | 12,200 | 11,143 – 13,304 | | |
| ROC | 10,043 | 9,997 – 10,089 | | |
| Cost per outpatient CAP case | | | | |
| 50-64 years | 109.58 | 82.19 – 136.98* | | CIHI 2007; Government of Alberta 2019; Ontario Schedule of Benefits; Yan et al 2017; ⁵⁶⁻⁵⁹ Excluding medication costs |
| 65+ years | 125.84 | 94.38 – 157.30 | CIHI 2007; Government of Alberta 2019; Ontario Schedule of Benefits; Yan et al 2017; ⁵⁶⁻⁵⁹ Including medication costs | |
| Out-of-pocket medication costs (<65 years) | 18.06 | 13.55 – 22.58* | Ontario Drug Benefit ⁶⁰ | |
| Annual cost of care for those with auditory sequelae | 2,783.33 | 2,087.50 – 3,479.16* | Christensen 2014 ⁴¹ | |
| Annual cost of care for those with neurologic sequelae | 9,262.42 | 6946.82 – 11,578.03* | | |

| Parameter | Base | Range | Reference |
|--|-------|-----------------|--|
| Cost of transportation to inpatient care | | | |
| Northern Canada | 7,573 | 3,001 – 12,189* | DAD 2015-2019; Glauser 2015; Government of Northwest Territories 2018; Government of Nunavut; Rendell 2016; Tam 2009 ^{36-39, 61-65} |
| ROC | 396 | 199 – 592* | DAD 2015-2019; Canada Revenue Agency 2022; Colbert 2020; Government of Prince Edward Island 2021; Government of Saskatchewan; Pong and Pitblado 2005 ^{36-39, 66-70} |
| Cost of transportation to outpatient care | | | |
| Northern Canada | 122 | 91 – 152* | Government of Yukon; Pong and Pitblado 2005 ^{70, 71} |
| ROC | 0 | | Assumed to be out-of-pocket |
| Daily cost of travel subsidy for overnight stay | | | |
| Northern Canada | 155 | 78 – 310* | Government of Yukon ⁷¹ |
| ROC | 0 | | |

*Range defined as $\pm 25\%$ of base case value

Table 7. Indirect cost parameters

| Parameter | Base | Range | Reference |
|----------------------------------|--------|------------------|--|
| Productivity loss | | | |
| Hospitalization | | | |
| 50-64 years | 3,237 | 2,427 – 4,046* | Pasquale et al 2019; Statistics Canada 2020 ^{72, 73} |
| 65+ years | 338 | 254 – 423* | |
| Outpatient (CAP) | | | |
| 50-64 years | 965 | 724 – 1,206* | Pasquale et al 2019; Statistics Canada 2020 ^{72, 73} |
| 65+ years | 101 | 76 – 126* | |
| Auditory sequelae (annual) | | | |
| 50-64 years | 19,004 | 14,253 – 23,755* | Assumption based on Bizier et al 2016; Statistics Canada 2020 ^{73, 74} |
| 65+ years | 1,983 | 1,487 – 2,479* | |
| Neurologic sequelae (annual) | | | |
| 50-64 years | 54,228 | 40,671 – 67,785* | Based on assumption of 100% productivity loss Statistics Canada 2020 ⁷³ |
| 65+ years | 5,660 | 4,245 – 7,075* | |
| Cost of caregiver support | | | |
| Recovering inpatient | 1,233 | 925 – 1,541* | Hollander et al 2019; Wyrwich et al 2015 ^{75, 76} |
| Recovering outpatient | 0 | | Assumption |
| Neurologic sequelae | 60,048 | 45,036 – 75,060* | Ganapathy et al 2015; Hollander et al 2019 ^{75, 77} |

*Range defined as $\pm 25\%$ of base case value.

Table 8. Health utility multipliers

| Parameter | Base | Range | Reference |
|---------------------|--------|-----------------|---|
| Hospitalization | 0.8659 | 0.8323 – 0.8963 | Mangen et al 2017 ⁴⁵ |
| Outpatient pCAP* | 0.9938 | 0.9917 – 0.9956 | Oppong et al 2013a; Oppong et al 2013b ^{46, 47} |
| Auditory sequelae | 0.6850 | 0.6214 – 0.7451 | Galante et al 2011 ⁵⁰ |
| Neurologic sequelae | 0.3441 | 0.2725 – 0.4164 | Galante et al 2011 ⁵⁰ |

II.3 Base Case

Health outcomes, compared to projected outcomes with use of PNEU-P-23 in the population, are displayed graphically in [Figure 2](#) by cohort age and region. For all age cohorts and geographic regions, use of PNEU-C-20, alone or in series with PNEU-P-23 and use of PNEU-C-15 in series with PNEU-P-23, were projected to avert cases of IPD, pCAP, as well as pneumococcal-attributable hospitalizations and deaths, compared to continued use of PNEU-P-23. In the age 50 cohort, use of PNEU-C-15 alone was projected to result in more cases of IPD than use of PNEU-P-23. For all other ages and outcomes, PNEU-C-15 was projected to result in fewer cases of IPD, pCAP, hospitalizations, and deaths compared to PNEU-P-23.

Figure 2. Health outcomes averted with different vaccination strategies compared to PNEU-P-23 use



Outcomes are summed across the lifespan of the individuals in the indicated age cohort for the different vaccination strategies and compared to rates in a cohort vaccinated with PNEU-P-23. Results are shown separately for the North and rest of Canada. For the vaccinate at age 50 strategy, use of PNEU-C-15 was projected to result in more IPD cases than current recommendations (outlined in red). Note that the x-axes vary across graphs.

Unless noted otherwise, results are presented for the health system perspective. Mean costs, QALYs, and ICERs from the base case health system perspective are presented in [Table 9](#). Incremental cost-effectiveness ratios show the costs per QALY gained when comparing each vaccination strategy directly to current recommendations (PNEU-P-23). The sequential ICERs compare all of the different possible vaccination strategies for a given age cohort and geographic region, excluding those that are either dominated or subject to extended dominance. In the sequential analysis, strategies that, when compared to the current recommendation only, may have ICERs considered cost-effective by commonly used thresholds, may be excluded because there are other strategies that represent better value for money, regardless of the cost-effectiveness threshold used. For instance, for the rest of Canada, the ICER for vaccinating at age 65 with PNEU-C-15 compared to PNEU-P-23 is \$34,852 per QALY gained. However, compared to PNEU-C-20 use in the same population, PNEU-C-15 is dominated, because it is more costly and results in fewer QALYs gained than PNEU-C-20. If PNEU-C-20 is available, it would be the preferred option based on the parameters and assumptions used for this analysis.

Mean costs and QALYs are also displayed graphically in [Figure 3](#) by cohort age, region, and perspective. Across cohort ages, regions, and perspective, the efficiency frontier consisted of PNEU-P-23 and PNEU-C-20 (either alone or in series with PNEU-P-23). ICERs ranging from \$6,529 to \$113,514 per QALY from the health system perspective. ICERs were higher in younger age cohorts due to lower risk of disease and waning vaccine protection as risk increased with age. ICERs were generally lower in Northern Canada due to the higher burden of disease and higher costs associated with illness. Higher ICERs in the Northern Canada age 75 years cohort were likely due to lower life expectancy in this region.

Table 9. Base case, health system perspective: mean costs, quality-adjusted life years, and incremental cost-effectiveness ratios

| Strategy | Cost (per 100,000) (\$) | QALYs (per 100,000) | Sequential ICER (\$/QALY) | ICER (vs PNEU-P-23) (\$/QALY) |
|---|-------------------------|---------------------|---|-------------------------------|
| Vaccinate at age 50 years, ROC | | | | |
| PNEU-P-23 | 50,484,326 | 2,077,705 | | |
| PNEU-C-20 | 52,597,378 | 2,077,765 | 35,619 | 35,619 |
| PNEU-C-20 + PNEU-P-23 | 54,143,528 | 2,077,784 | 81,866 | 46,787 |
| PNEU-C-15 | 52,591,732 | 2,077,722 | Subject to extended dominance between PNEU-P-23 and PNEU-C-20 | 127,065 |
| PNEU-C-15 + PNEU-P-23 | 53,877,523 | 2,077,762 | Dominated by PNEU-C-20 | 60,515 |
| Vaccinate at age 50 years, Northern Canada | | | | |
| PNEU-P-23 | 61,632,445 | 1,115,424 | | |
| PNEU-C-20 | 62,514,745 | 1,115,478 | 16,300 | 16,300 |
| PNEU-C-20 + PNEU-P-23 | 63,619,038 | 1,115,498 | 57,003 | 27,028 |
| PNEU-C-15 | 63,439,141 | 1,115,436 | Dominated by PNEU-C-20 | 153,970 |
| PNEU-C-15 + PNEU-P-23 | 63,818,745 | 1,115,477 | Dominated by PNEU-C-20 | 41,367 |
| Vaccinate at age 65 years, ROC | | | | |
| PNEU-P-23 | 46,833,041 | 1,369,927 | | |
| PNEU-C-20 | 48,602,290 | 1,370,029 | 17,379 | 17,379 |
| PNEU-C-20 + PNEU-P-23 | 50,151,922 | 1,370,049 | 80,344 | 27,409 |
| PNEU-C-15 | 48,613,991 | 1,369,979 | Dominated by PNEU-C-20 | 34,852 |
| PNEU-C-15 + PNEU-P-23 | 49,909,479 | 1,370,020 | Dominated by PNEU-C-20 | 33,077 |
| Vaccinate at age 65 years, Northern Canada | | | | |
| PNEU-P-23 | 52,151,455 | 552,531 | | |
| PNEU-C-20 | 52,563,675 | 552,594 | 6,529 | 6,529 |

| Strategy | Cost (per 100,000) (\$) | QALYs (per 100,000) | Sequential ICER (\$/QALY) | ICER (vs PNEU-P-23) (\$/QALY) |
|---|-------------------------|---------------------|---------------------------|-------------------------------|
| PNEU-C-20 + PNEU-P-23 | 53,667,380 | 552,608 | 79,986 | 19,704 |
| PNEU-C-15 | 53,367,564 | 552,559 | Dominated by PNEU-C-20 | 43,038 |
| PNEU-C-15 + PNEU-P-23 | 53,815,043 | 552,590 | Dominated by PNEU-C-20 | 28,178 |
| Vaccinate at age 75 years, ROC | | | | |
| PNEU-P-23 | 39,732,906 | 907,517 | | |
| PNEU-C-20 | 41,603,714 | 907,652 | 13,854 | 13,854 |
| PNEU-C-20 + PNEU-P-23 | 43,602,551 | 907,676 | 83,788 | 24,353 |
| PNEU-C-15 | 41,848,301 | 907,586 | Dominated by PNEU-C-20 | 30,817 |
| PNEU-C-15 + PNEU-P-23 | 43,428,274 | 907,638 | Dominated by PNEU-C-20 | 30,551 |
| Vaccinate at age 75 years, Northern Canada | | | | |
| PNEU-P-23 | 44,082,577 | 295,298 | | |
| PNEU-C-20 | 44,871,091 | 295,348 | 15,757 | 15,757 |
| PNEU-C-20 + PNEU-P-23 | 46,136,622 | 295,359 | 113,514 | 33,567 |
| PNEU-C-15 | 45,820,090 | 295,320 | Dominated by PNEU-C-20 | 79,463 |
| PNEU-C-15 + PNEU-P-23 | 46,299,566 | 295,344 | Dominated by PNEU-C-20 | 47,582 |

Figure 3. Base case mean costs and QALYs over 2,000 simulations stratified by age cohort and region

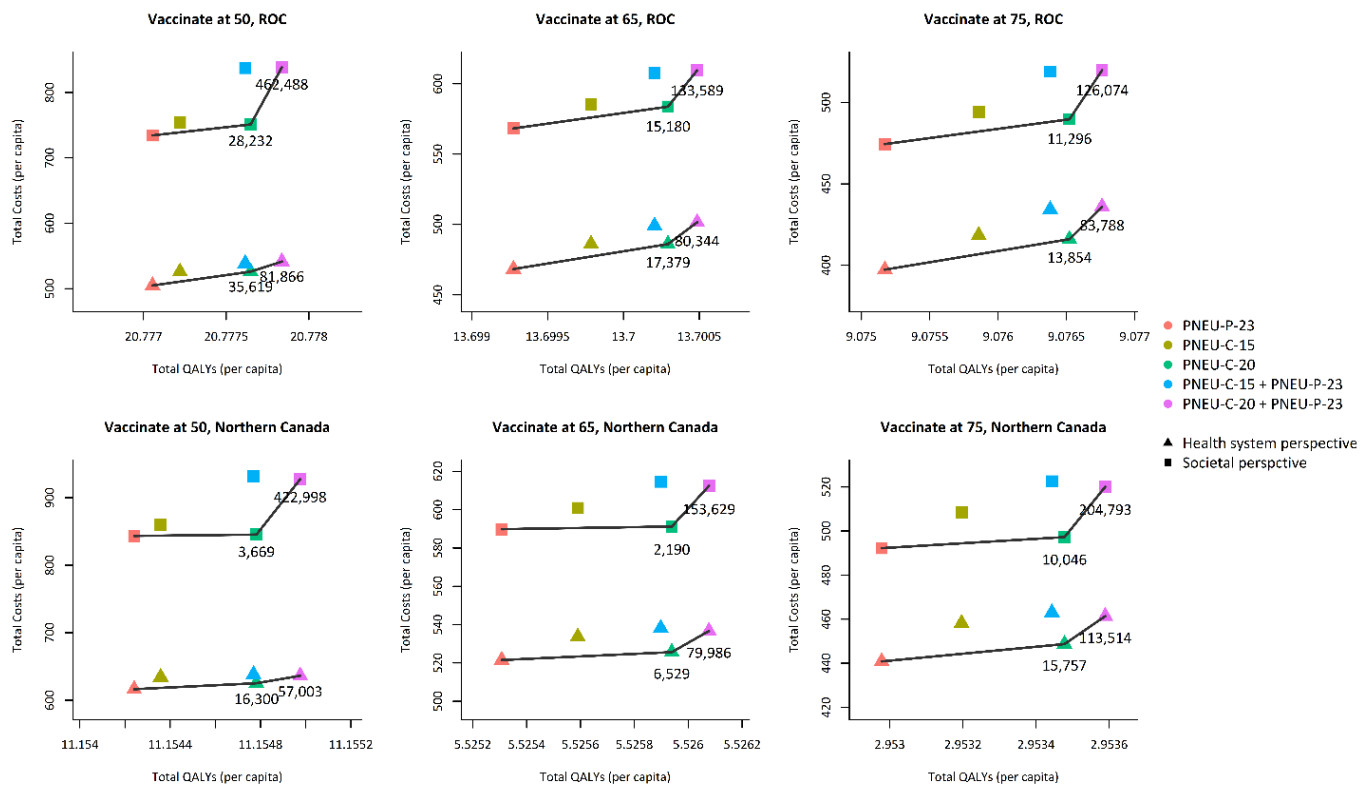

Each plot shows the efficiency frontier from the health system perspective (▲) and the societal perspective (■). The efficiency frontier is marked by a solid line connecting the set of potentially cost-effective strategies, depending on the cost-effectiveness threshold value. ICERs are labelled below each strategy on the efficiency frontier and are represented by the slope of the line connecting the strategy with the next most effective strategy on the frontier. Strategies that are not on the efficiency frontier are not considered cost-effective at any threshold value and for this reason, ICERs are not shown. Note that the scales for the x- and y-axes vary across graphs.

Figure 4 displays the proportion of simulations for which each strategy was the optimal strategy over a range of cost-effectiveness threshold values. In Northern Canada, PNEU-C-20 was the optimal strategy in greater than 50% of simulations at threshold ranges of \$16,700-58,800, \$7,400-87,100, and \$16,600-125,600, in the age 50, 65, and 75 years cohorts, respectively. In ROC, PNEU-C-20 was the optimal strategy in greater than 50% of simulations at threshold ranges of \$36,000-85,100, \$17,400-87,900, and \$14,100-93,100, in the age 50, 65, and 75 years cohorts, respectively. In Northern Canada, PNEU-C-20 in series with PNEU-P-23 was the optimal strategy in the majority of simulations at thresholds above \$67,100 (age 50 years), \$92,800 (age 65 years), and \$141,000 (age 75 years). In ROC, PNEU-C-20 in series with PNEU-P-23 was the optimal strategy in the majority of simulations at thresholds above \$92,800 (age 50 years), \$90,700 (age 65 years), and \$97,100 (age 75 years). PNEU-C-15 did not appear as the optimal strategy in any of the simulations. PNEU-C-15 in series with PNEU-P-23 was the optimal strategy in <1-2% of simulations and at thresholds >\$100,000 per QALY gained.

Figure 4. Percent of simulations that each strategy was the optimal strategy at a given cost-effectiveness threshold

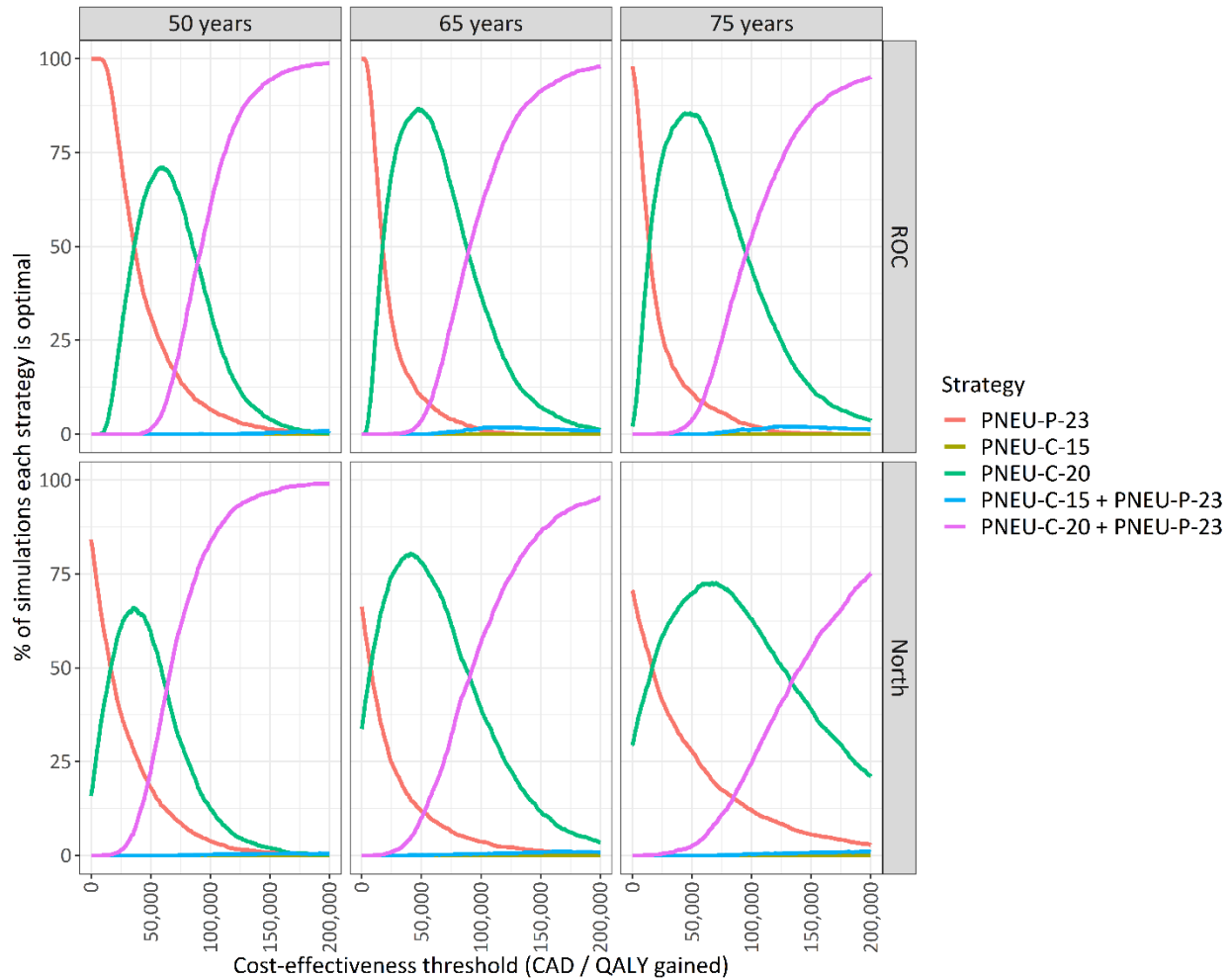

Results are shown for each age cohort and geographic region.

II.4 Sensitivity Analysis

Deterministic univariate sensitivity analysis was performed for key model parameters by varying model parameters one at a time over the ranges listed in [Tables 3 to 8](#) while holding all other parameter values at their base case values ([Figures 5 and 6](#)). Vaccine effectiveness parameters were tested differently, with values for PNEU-C-15/20 and PNEU-P-23 constrained to ensure that PNEU-C-15/20 would not be less effective than PNEU-P-23 during this test. The low effectiveness value of PNEU-C-15/20 was constrained to be no less than the base case value of the PNEU-P-23 and the high effectiveness value of PNEU-P-23 was constrained to be no greater than the base case value of PNEU-C-15/20. Vaccine prices were varied by $\pm 50\%$ of the base case value. Results are presented as ICERs of PNEU-C-15 + PNEU-P-23 or PNEU-C-20 compared to PNEU-P-23.

The model showed greater sensitivity to vaccination parameters, particularly when vaccine effectiveness against CAP was similar between the polysaccharide and conjugate vaccines. In

addition, the model showed greater sensitivity to vaccine price and discount rate. Larger variations in the ICER were observed in Northern Canada compared to the rest of Canada.

Figure 5. Deterministic univariate sensitivity analysis comparing PNEU-C-15 + PNEU-P-23 with PNEU-P-23

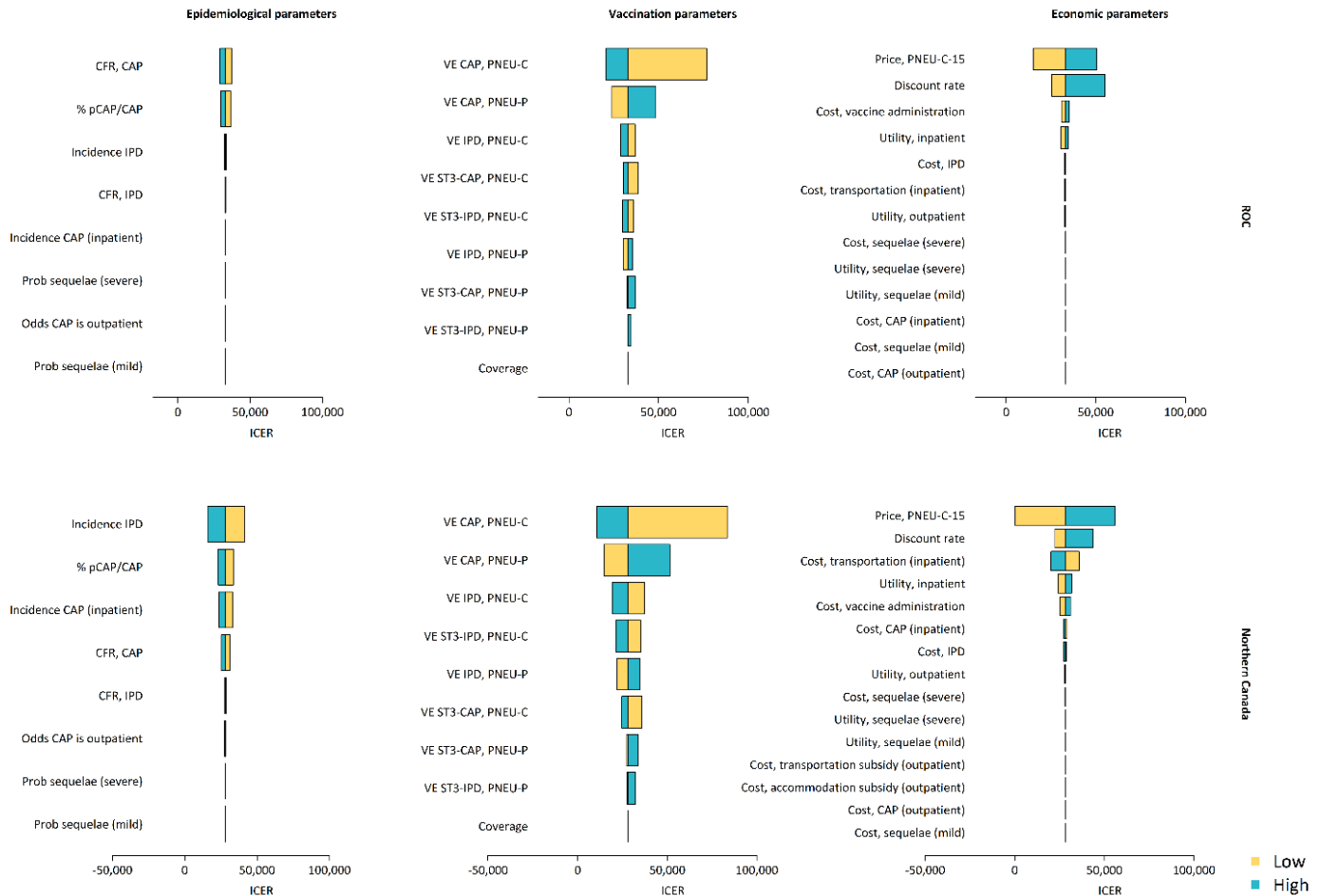

Each parameter value was varied between a low and high value while holding all other parameters at their base case values. Differences in the base case ICERs compared to [Table 9](#) are a result of deterministic (rather than probabilistic) estimates in the univariate sensitivity analysis.

CAP = community-acquired pneumonia; CFR = case fatality rate; IPD = invasive pneumococcal disease; % pCAP/CAP = proportion of CAP cases attributable to *S. pneumoniae*; VE = vaccine effectiveness; PCV = pneumococcal conjugate vaccine; PPV = pneumococcal polysaccharide vaccine; ST3 = serotype 3

Figure 6. Deterministic univariate sensitivity analysis comparing PNEU-C-20 with PNEU-P-23

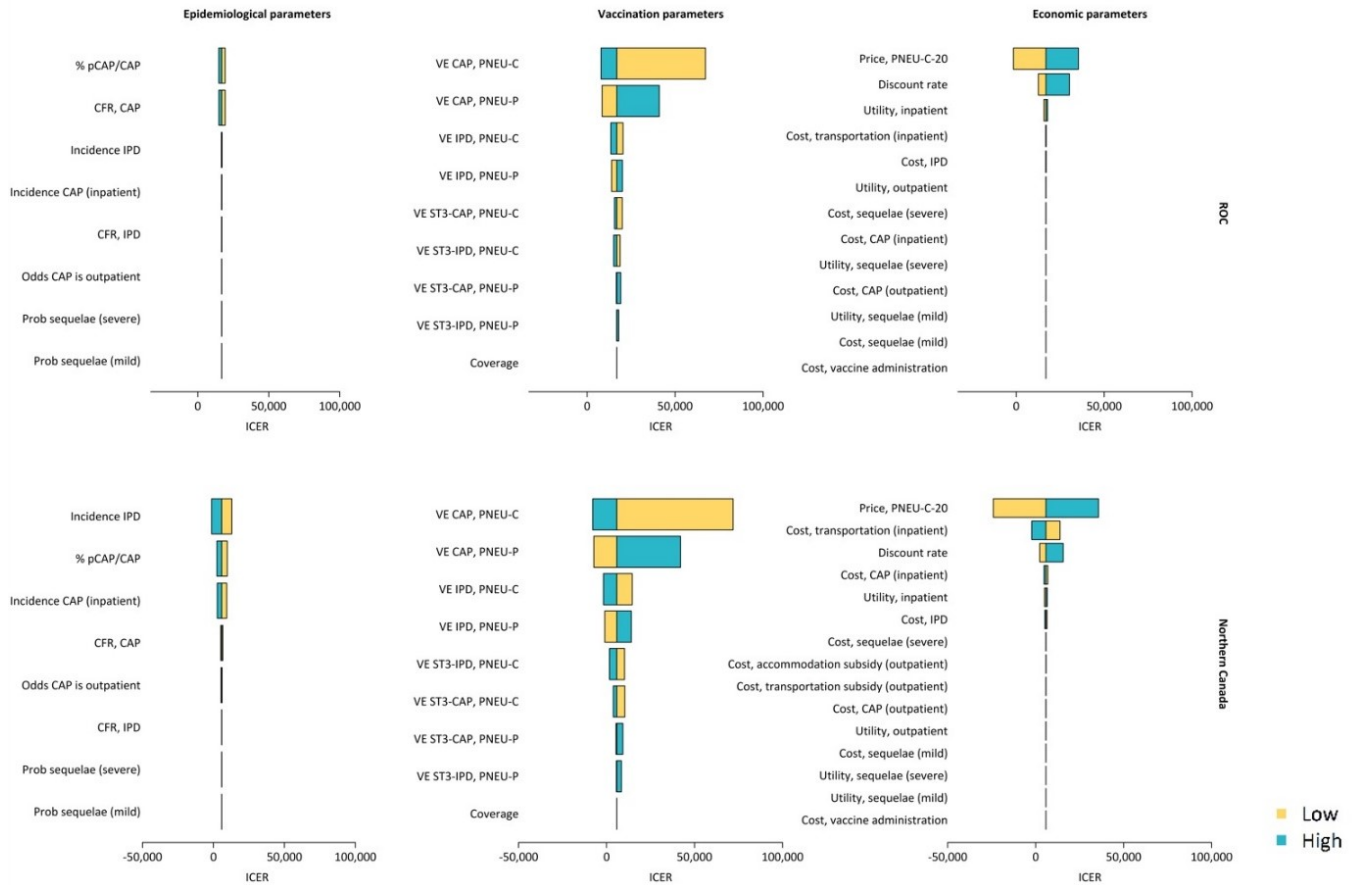

Each parameter value was varied between a low and high value while holding all other parameters at their base case values. Differences in the base case ICERs compared to [Table 9](#) are a result of deterministic (rather than probabilistic) estimates in the univariate sensitivity analysis.

CAP = community-acquired pneumonia; CFR = case fatality rate; IPD = invasive pneumococcal disease; % pCAP/CAP = proportion of CAP cases attributable to *S. pneumoniae*; VE = vaccine effectiveness; PCV = pneumococcal conjugate vaccine; PPV = pneumococcal polysaccharide vaccine; ST3 = serotype 3

II.5 Scenario Analyses

Extensive scenario analyses were conducted to account for uncertainty in base case assumptions. Some key analysis are described below.

Indirect effects of a pediatric vaccination program with PNEU-C-15 and/or PNEU-C-20

Incidence of pneumococcal disease associated with serotypes unique to PNEU-C-15 or PNEU-C-20 were decreased to approximate indirect effects of a potential pediatric vaccination program with PNEU-C-15 or PNEU-C-20. Indirect effects were assumed to begin four years after vaccination of adults to account for a delay in initiating a pediatric program and time to observe an effect of reduced carriage. Indirect effects were modelled as a simple linear decline in PD incidence from unique PNEU-C-15/20 serotypes by 50% over 5 years. Potential serotype replacement was not modelled. [Figure 7](#) shows that inclusion of indirect effects resulted in ICERs that were higher compared to the base case. No change to the strategies on the efficiency frontier was observed compared to the base case.

Figure 7. Scenario analysis: indirect effects from a pediatric vaccination program

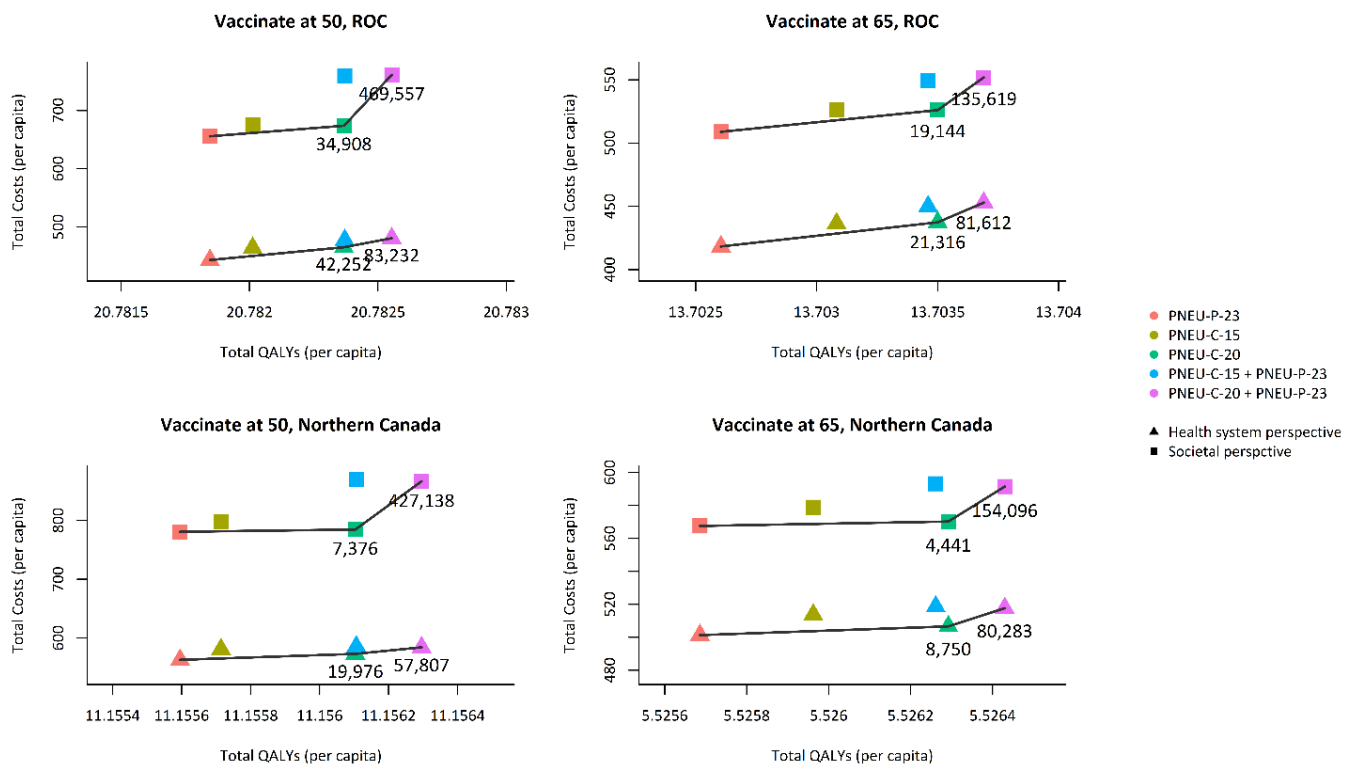

Each plot shows the efficiency frontier from the health system perspective (▲) and the societal perspective (■). The efficiency frontier is marked by a solid line connecting the set of potentially cost-effective strategies, depending on the cost-effectiveness threshold value. ICERs are labelled below each strategy on the efficiency frontier and are represented by the slope of the line connecting the strategy with the next most effective strategy on the frontier. Strategies that are not on the efficiency frontier are not considered cost-effective at any threshold value.

Faster waning of vaccine protection

This scenario examined the potential impact of faster waning protection compared to the base case. In this scenario, protection by the polysaccharide vaccine declined linearly to 0% over seven years (compared to 15 years in the base case). Protection by the conjugate vaccine was assumed to remain stable for the first five years and then declined to 0% over the next seven years (compared to 10 years in the base case). Lower ICERs were observed compared to the base case (Figure 8) and PNEU-P-23 was dominated by PNEU-C-20 at age 65 years in Northern Canada and at age 50 years in Northern Canada from the societal perspective.

Figure 8. Scenario analysis: faster waning of vaccine protection

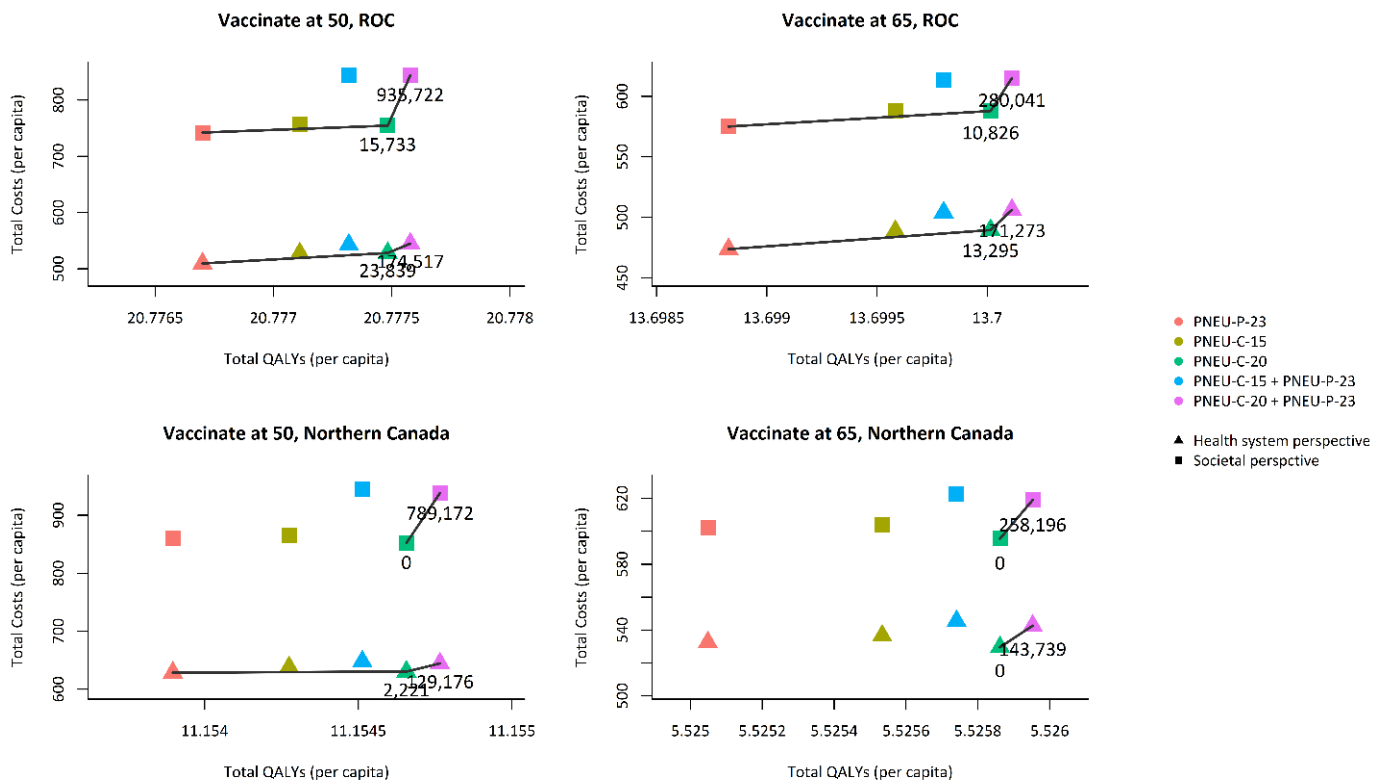

Each plot shows the efficiency frontier from the health system perspective (▲) and the societal perspective (■). The efficiency frontier is marked by a solid line connecting the set of potentially cost-effective strategies, depending on the cost-effectiveness threshold value. ICERs are labelled below each strategy on the efficiency frontier and are represented by the slope of the line connecting the strategy with the next most effective strategy on the frontier. Strategies that are not on the efficiency frontier are not considered cost-effective at any threshold value.

PNEU-C-15 effectiveness versus serotype 3

This scenario examined the potential impact of higher effectiveness of PNEU-C-15 for preventing pneumococcal disease due to serotype 3, based on GMT ratios⁷⁸. Vaccine effectiveness values for this scenario are listed in Table 10. Higher effectiveness of PNEU-C-15 against serotype 3 PD

resulted in lower ICERs of PNEU-C-15 (alone or in series with PNEU-P-23) compared to PNEU-P-23 than in the base case analysis but did not result in PNEU-C-15 appearing on the efficiency frontier (Figure 9). No other changes to the strategies on the efficiency frontier were observed.

Table 10. Vaccine effectiveness values for scenario analysis of PNEU-C-15 against pneumococcal disease caused by serotype 3

| Parameter | Base Value | Range |
|---|------------|-------------|
| Vaccine effectiveness against serotype 3 IPD | | |
| PNEU-P-23 | 2.0 | 0 – 21.0 |
| PNEU-C-15 | 46.0 | 18.1 – 75.5 |
| PNEU-C-20 | 26.0 | 0 – 53.4 |
| Vaccine effectiveness against serotype 3 CAP | | |
| PNEU-P-23 | 2.0 | 0 – 21.0 |
| PNEU-C-15 | 27.6 | 18.4 – 37.9 |
| PNEU-C-20 | 15.6 | 0 – 22.7 |

Figure 9. Scenario analysis: higher PNEU-C-15 vaccine effectiveness against pneumococcal disease caused by serotype 3

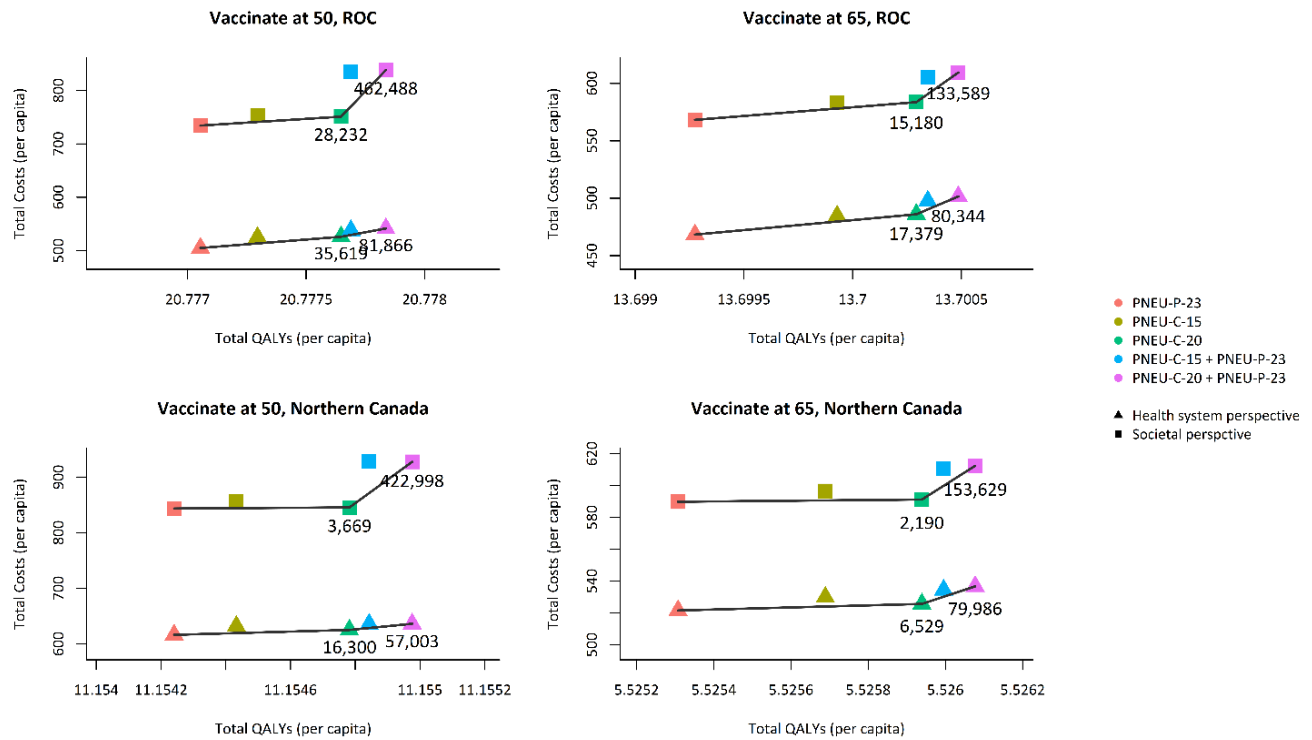

Each plot shows the efficiency frontier from the health system perspective (▲) and the societal perspective (■). The efficiency frontier is marked by a solid line connecting the set of potentially cost-effective strategies, depending on the cost-effectiveness threshold value. ICERs are labelled below each strategy on the efficiency frontier and are represented by the slope of the line connecting the strategy with the next most effective strategy on the frontier. Strategies that are not on the efficiency frontier are not considered cost-effective at any threshold value.

Vaccine price

Given the sensitivity of model results to vaccine prices and uncertainty about prices for PNEU-C-15 and PNEU-C-20, the influence of vaccine prices on optimal vaccination strategy was further explored in a two-way sensitivity analysis. We determined the point at which the prices for PNEU-C-15, PNEU-C-20, and PNEU-P-23 would have equivalent cost-effectiveness (i.e., the use of one particular vaccination strategy was no longer preferred). The vaccine prices for PNEU-C-15 and PNEU-C-20 were varied relative to the assumed price for PNEU-P-23. The optimal strategies were determined for the age 50 and 65 years cohorts for cost-effectiveness thresholds of \$30,000 and \$60,000 per QALY gained. At a threshold of \$30,000 per QALY gained, PNEU-P-23, PNEU-C-15, and PNEU-C-20 would be equivalent cost-effective strategies at incremental prices (relative to an assumed fixed price for PNEU-P-23) of PNEU-C-15 and PNEU-C-20 of \$14 and \$51 per dose, respectively, in the age 50 years cohort. In the age 65 years cohort, the strategies would be equivalent at incremental prices of \$41 (PNEU-C-15) and \$84 (PNEU-C-20) per dose. At a threshold of \$60,000 per QALY gained, PNEU-P-23, PNEU-C-15 + PNEU-P-23, and PNEU-C-20 would be equivalent strategies at incremental prices of \$46 (PNEU-C-15) and \$88 (PNEU-C-20) per dose in the age 50 years cohort. In the age 65 years cohort, the strategies would be equivalent at incremental prices of \$99 (PNEU-C-15) and \$148 (PNEU-C-20) per dose. Based on this analysis, the price per dose of PNEU-C-15 may need to be approximately \$40-50 less than that of PNEU-C-20 for the use of PNEU-C-15 to be cost effective.

II.6 Study limitations

There are a number of limitations to this study. A significant limitation is the lack of comparative effectiveness data between PNEU-C-15 and PNEU-C-20. As a result, the dominance of PNEU-C-20 is driven by the broader serotype coverage under an assumption of equivalent effectiveness to PNEU-C-13 serotypes. In addition, the nature of waning protection with PNEU-C-15 and PNEU-C-20 are unknown. Although the model results appear robust in scenario analysis of vaccine waning, the strategies on the efficiency frontier may change if waning is markedly different between the two conjugate vaccines.

The effect of vaccination on transmission could not be assessed due to the static cohort design. There is considerable uncertainty associated with the possible future use of higher valency pneumococcal vaccines in pediatric vaccination programs, in terms of reduction in vaccine-type PD and potential serotype replacement, which could influence the cost-effectiveness of an adult program.

The model did not stratify the population by underlying medical conditions or immunocompromised status due to limited data in these groups at the national level. These groups may have a higher burden of disease and higher medical costs per case. Cost-effectiveness of the conjugate vaccines in groups without underlying medical or

immunocompromising conditions may be overestimated as the costs and benefits are aggregated over the entire population.

There is some data suggesting that vaccination may reduce the occurrence of cardiac events following pneumonia^{79, 80}. Due to uncertainty about the nature of this protective effect, this outcome was not included in the model and this exclusion may underestimate the benefits of vaccination with PNEU-C-15 or PNEU-C-20. In this case, these study results would be a conservative estimate of the cost-effectiveness of PNEU-C-15 and PNEU-C-20.

Societal costs were likely underestimated as non-medical consumption and caregiver costs associated with auditory sequelae were not included due to uncertainty about the effect of pneumococcal disease and auditory sequelae on these costs. Given these limitations, the study results may be viewed as a conservative estimate of the cost-effectiveness of PNEU-C-15 and PNEU-C-20 from a societal perspective.

II.7 Conclusions

The base case model and scenario analyses indicate that PNEU-C-20 (either alone or in series with PNEU-P-23) is likely a cost-effective strategy at age 65 or age 75 years. In the base case, using a health system perspective, ICERs for the use of PNEU-C-20 alone ranged from \$6530 to \$17,400 per QALY gained in these age cohorts. Base case ICERs for PNEU-C-20 at age 50 years ranged from \$16,300 to \$35,600 per QALY gained using the health system perspective. PNEU-C-15 was dominated or subject to extended dominance across most scenarios and does not appear to be a cost-effective strategy while PNEU-P-23 or PNEU-C-20 are available.

III. MULTI-MODEL COMPARISON

III.1 Approach

To evaluate the robustness of the cost-utility model described in [Section 2](#), a multi-model comparison was conducted. Outputs from different economic models were compared to identify areas of consistency and difference across models with different structures and assumptions. Two additional cost-utility models were identified that were adapted to evaluate the cost-effectiveness of age-based vaccination strategies in the Canadian population. Both models were funded by industry. Versions of the Merck⁸ and Pfizer⁹ models were described in the systematic review ([Section 1](#)) and were used in economic evaluations of PNEU-C-15 and/or PNEU-C-20 in the United States. Wherever possible, these models incorporated the same parameters as used in the previously described Canadian cost-utility model, although differences in the model structures required some modifications or simplifying assumptions, as described in [Table 11](#). All models were adapted to represent a general population and did not include stratification by chronic medical or immunocompromising conditions.

Table 11. Summary of key differences in models used in multi-model comparison.

| Model feature | Merck | Pfizer | NACI |
|--|---------------|---------------------|---------------|
| Model type | Single cohort | Multiple-age cohort | Single cohort |
| Lower vaccine effectiveness for serotype 3 than other serotypes | Yes | No | Yes |
| Costs and health consequences of post-meningitis sequelae included | Yes | No | Yes |

For the multi-model comparison, results from a single base case were generated and sensitivity analysis were not conducted. A health system perspective was adopted and all models used a lifetime time horizon. Indirect effects of a potential pediatric vaccination program were not included for this comparison. For a given age recommendation and region, sequential ICERs were calculated, to allow for a comparison across different vaccination strategies and identify options that would be most cost-effective. Results for the multi-model comparison are summarized in aggregate below to avoid possible disclosure of confidential information.

III.2 Multi-Model Comparison Results

Results were broadly consistent across the different models. Differences in estimates across models likely reflected differences in model structure and simplifying assumptions made for the purposes of the multi-model comparison. Despite quantitative variability in ICER estimates across models, qualitative results were consistent.

In the sequential analysis of all vaccination strategies, all models estimated that PNEU-C-15 or PNEU-C-15 in series with PNEU-P-23 would be dominated or subject to extended dominance by PNEU-C-20. This was consistent across ages and regions.

All three models indicated that use of PNEU-C-20 is likely a cost-effective strategy at age 50 years and 65 years, with ICERs ranging from \$5,000 to \$40,000 per QALY across models and geographic regions. At age 75, results for the use of PNEU-C-20 were variable, with ICERs ranging from \$11,000 to \$105,000 per QALY gained. All models placed PNEU-C-20 in series with PNEU-P-23 on the efficiency frontier for all ages and regions, suggesting that this strategy could be considered cost-effective, depending on the threshold used.

III.3 Conclusions

Three cost-utility models with harmonized parameter values showed qualitatively consistent results despite differing model structures and assumptions. The comparison supported the finding that, based on currently available data, PNEU-C-20, used alone or in series with PNEU-P-23 could be a cost-effective strategy for use in the adult Canadian population.

List of Abbreviations

| | |
|------------------|--|
| ACIP | Advisory Committee on Immunization Practices |
| CADTH | Canadian Agency for Drugs and Technologies in Health |
| CAP | Community-acquired pneumonia |
| CFR | Case fatality rate |
| CMC | Chronic medical conditions |
| CNDSS | Canadian Notifiable Disease Surveillance System |
| DAD | Discharge Abstract Database |
| IC | Immunocompromising conditions |
| ICER | Incremental cost-effectiveness ratio |
| ICS | International Circumpolar Surveillance |
| IPD | Invasive pneumococcal disease |
| NVT | Non-vaccine type |
| pCAP | Pneumococcal Community Acquired Pneumonia |
| PCV | Pneumococcal conjugate vaccine |
| PD | Pneumococcal disease |
| PNEU-C-13 | 13-valent pneumococcal conjugate vaccine |
| PNEU-C-15 | 15-valent conjugate pneumococcal vaccine |
| PNEU-C-20 | 20-valent conjugate pneumococcal vaccine |
| PNEU-P-23 | 23-valent pneumococcal polysaccharide vaccine |
| PPV | Pneumococcal polysaccharide vaccine |

| | |
|-------------|----------------------------|
| QALY | Quality-adjusted life year |
| ROC | Rest of Canada |
| ST3 | Serotype 3 |
| US | United States |
| VE | Vaccine effectiveness |
| VT | Vaccine-type |

References

1. CADTH Research Information Services. Grey Matters: a practical tool for searching health-related grey literature [Internet]. Ottawa (ON): 2022 Jun 20 [cited 2022 Jun 16]. Available from: <https://www.cadth.ca/grey-matters-practical-tool-searching-health-related-grey-literature>.
2. Evidence Partners. DistillerSR: Literature Review Software - Canada. [Internet]. Ottawa (ON): DistillerSR; 2022 [cited 2022 Jun 16]. Available from: <https://www.evidencepartners.com/products/distillersr-systematic-review-software>.
3. U.S. Bureau of Economic Analysis. Personal consumption expenditures: Services: Health care (chain-type price index) [Internet]. St. Louis (MO): Federal Reserve Bank of St. Louis; 2022 May 26 [cited 2022 Jun 16]. Available from: <https://fred.stlouisfed.org/series/DHLCRG3Q086SBEA>.
4. The Joanna Briggs Institute. The Joanna Briggs Institute Critical Appraisal tools for use in JBI Systematic Reviews: Checklist for Economic Evaluations [Internet]. Adelaide (SA). 2017 [cited 2022 Jun 16]. Available from: https://jbi.global/sites/default/files/2019-05/JBI_Critical_Appraisal-Checklist_for_Economic_Evaluations2017_0.pdf.
5. Heyland DK, Kernerman P, Gafni A, Cook DJ. Economic evaluations in the critical care literature: do they help us improve the efficiency of our unit? *Crit Care Med*. 1996 Sep;24(9):1591,1598. doi: 10.1097/00003246-199609000-00025.
6. Smith KJ, Wateska AR, Nowalk MP, Lin CJ, Harrison LH, Schaffner W, et al. Higher-Valency Pneumococcal Conjugate Vaccines: An Exploratory Cost-Effectiveness Analysis in U.S. Seniors. *Am J Prev Med*. 2021 Jul;61(1):28,36. doi: 10.1016/j.amepre.2021.01.023.
7. Leidner AJ. Summary of three economic models assessing pneumococcal vaccines in US adults [Internet]. Atlanta (GA): Centers for Disease Control and Prevention; 2021 Sep 29 [cited 2022 Jun 16]. Available from: <https://www.cdc.gov/vaccines/acip/meetings/downloads/slides-2021-09-29/02-Pneumococcal-Leidner-508.pdf>.
8. Owusu-Edusei K, Deb A, Johnson K, Sharomi O, Elbasha E, Weiss T, et al. Summary of three economic models assessing pneumococcal vaccines in US adults [Internet]. Atlanta (GA): Centers for Disease Control and Prevention; 2021 Sep 29 [cited 2022 Jun 16]. Available from: <https://www.cdc.gov/vaccines/acip/meetings/downloads/slides-2021-09-29/02-Pneumococcal-Leidner-508.pdf>.
9. Weycker D, Averin A, Atwood M, Shaff M, Sato R, Chilson E, et al. Summary of three economic models assessing pneumococcal vaccines in US adults [Internet]. Atlanta (GA): Centers for Disease Control and Prevention; 2021 Sep 29 [cited 2022 Jun 16]. Available from: <https://www.cdc.gov/vaccines/acip/meetings/downloads/slides-2021-09-29/02-Pneumococcal-Leidner-508.pdf>.
10. Stoecker C, Kobayashi M, Cho B-H, Pilishvili T. Summary of three economic models assessing pneumococcal vaccines in US adults [Internet]. Atlanta (GA): Centers for Disease Control and Prevention; 2021 Sep 29 [cited 2022 Jun 16]. Available from: <https://www.cdc.gov/vaccines/acip/meetings/downloads/slides-2021-09-29/02-Pneumococcal-Leidner-508.pdf>.

11. Stoecker C. Economic assessment of PCV15 & PCV20 [Internet]. Atlanta (GA): Centers for Disease Control and Prevention; 2021 Jun 25 [cited 2022 Jun 16]. Available from: <https://stacks.cdc.gov/view/cdc/109109>.
12. Matanock A, Lee G, Gierke R, Kobayashi M, Leidner A, Pilishvili T. Use of 13-Valent Pneumococcal Conjugate Vaccine and 23-Valent Pneumococcal Polysaccharide Vaccine Among Adults Aged ≥ 65 Years: Updated Recommendations of the Advisory Committee on Immunization Practices. *MMWR Morb Mortal Wkly Rep.* 2019 Nov 22;68(46):1069,1075. doi: 10.15585/mmwr.mm6846a5.
13. National Advisory Committee on Immunization. Guidelines for the Economic Evaluation of Vaccination Programs in Canada. Draft 1st ed. [Unpublished]. Ottawa (ON): Public Health Agency of Canada; 2022.
14. Statistics Canada. Life Tables, Canada, Provinces and Territories 1980/1982 to 2018/2020 (three-year estimates), and 1980 to 2020 (single-year estimates) [Internet]. Ottawa (ON). 2022 Jan 24 [cited 2022 Jun 16]. Available from: <https://www150.statcan.gc.ca/n1/pub/84-537-x/84-537-x2021001-eng.htm>.
15. R Core Team. R: A language and environment for statistical computing. 4.0 ed. [Internet]. Vienna (AT): R Foundation for Statistical Computing; 2020 [cited 2022 Oct 7]. Available from: <https://www.r-project.org/foundation/>.
16. Dowle M, Srinivasan A. data.table: Extension of 'data.frame'. R package version 1.14.2 [Internet]. Vienna (AT): R Foundation for Statistical Computing; 2021 Sep 27 [cited 2022 Oct 7]. Available from: <https://cran.r-project.org/web/packages/data.table/index.html>.
17. Krijkamp EM, Alarid-Escudero F, Enns EA, Pechlivanoglou P, Hunink MGM, Yang A, et al. A Multidimensional Array Representation of State-Transition Model Dynamics. *Med Decis Making.* 2020 Feb;40(2):242,248. doi: 10.1177/0272989X19893973.
18. Djennad A, Ramsay ME, Pebody R, Fry NK, Sheppard C, Ladhani SN, et al. Effectiveness of 23-Valent Polysaccharide Pneumococcal Vaccine and Changes in Invasive Pneumococcal Disease Incidence from 2000 to 2017 in Those Aged 65 and Over in England and Wales. *EClinicalMedicine.* 2019 Jan 1;6:42,50. doi: 10.1016/j.eclinm.2018.12.007.
19. IPD in Canada, 2011-2020. [Unpublished]. Ottawa (ON): Public Health Agency of Canada; 2022.
20. LeBlanc JJ, ElSherif M, Ye L, MacKinnon-Cameron D, Ambrose A, Hachette TF, et al. Recalibrated estimates of non-bacteremic and bacteremic pneumococcal community acquired pneumonia in hospitalized Canadian adults from 2010 to 2017 with addition of an extended spectrum serotype-specific urine antigen detection assay. *Vaccine.* 2022 Apr 20;40(18):2635,2646. doi: 10.1016/j.vaccine.2022.02.081.
21. Nelson JC, Jackson M, Yu O, Whitney CG, Bounds L, Bittner R, et al. Impact of the introduction of pneumococcal conjugate vaccine on rates of community acquired pneumonia in children and adults. *Vaccine.* 2008 Sep 8;26(38):4947,4954. doi: 10.1016/j.vaccine.2008.07.016.
22. Jokinen C, Heiskanen L, Juvonen H, Kallinen S, Karkola K, Korppi M, et al. Incidence of community-acquired pneumonia in the population of four municipalities in eastern Finland. *Am J Epidemiol.* 1993 May 1;137(9):977,988. doi: 10.1093/oxfordjournals.aje.a116770.

23. Mathijssen, Ignacio. Cost-effectiveness analysis of pneumococcal vaccinations among adults in the US. [Unpublished]. Whitehouse Station (NJ): Merck Sharp & Dohme Corp.; 2021.
24. Averin A, Atwood M, Weycker D, Kutrieb E, Lytle D, Zuraik C, et al. Cost-Effectiveness of 20-Valent Conjugate Vaccine in Canadian Adults: Technical Report Prepared for Pfizer Canada. [Unpublished]. Kirkland (QC): Pfizer Canada; 2021.
25. Wijayasri S, Hillier K, Lim GH, Harris TM, Wilson SE, Deeks SL. The shifting epidemiology and serotype distribution of invasive pneumococcal disease in Ontario, Canada, 2007-2017. *PLoS One*. 2019 Dec 13;14(12):e0226353. doi: 10.1371/journal.pone.0226353.
26. Backhaus E, Berg S, Andersson R, Ockborn G, Malmström P, Dahl M, et al. Epidemiology of invasive pneumococcal infections: manifestations, incidence and case fatality rate correlated to age, gender and risk factors. *BMC Infect Dis*. 2016 Aug 3;3(16):367. doi: 10.1186/s12879-016-1648-2.
27. Centres for Disease Control and Prevention. Active Bacterial Core Surveillance (ABCs) Report Emerging Infections Program Network *Streptococcus pneumoniae*, 2019 [Internet]. Atlanta (GA). 2019 [cited 2022 Jun 16]. Available from: https://www.cdc.gov/abcs/downloads/SPN_Surveillance_Report_2019.pdf.
28. Helferty M, Rotondo JL, Martin I, Desai S. The epidemiology of invasive pneumococcal disease in the Canadian North from 1999 to 2010. *Int J Circumpolar Health*. 2013 Aug 5;72. doi: 10.3402/ijch.v72i0.21606.
29. Brouwer MC, Heckenberg SG, de Gans J, Spanjaard L, Reitsma JB, van de Beek D. Nationwide implementation of adjunctive dexamethasone therapy for pneumococcal meningitis. *Neurology*. 2010 Oct 26;75(17):1533,1539. doi: 10.1212/WNL.0b013e3181f96297.
30. Heckenberg SG, Brouwer MC, van der Ende A, Hensen EF, van de Beek D. Hearing loss in adults surviving pneumococcal meningitis is associated with otitis and pneumococcal serotype. *Clin Microbiol Infect*. 2012 Sep;18(9):849,855. doi: 10.1111/j.1469-0691.2011.03668.x.
31. Hoogman M, van de Beek D, Weisfelt M, de Gans J, Schmand B. Cognitive outcome in adults after bacterial meningitis. *J Neurol Neurosurg Psychiatry*. 2007 Oct;78(10):1092,1096. doi: 10.1136/jnnp.2006.110023.
32. Lucas MJ, Brouwer MC, van de Beek D. Neurological sequelae of bacterial meningitis. *J Infect*. 2016 Jul;73(1):18,27. doi: 10.1016/j.jinf.2016.04.009.
33. Østergaard C, Konradsen HB, Samuelsson S. Clinical presentation and prognostic factors of *Streptococcus pneumoniae* meningitis according to the focus of infection. *BMC Infect Dis*. 2005 Oct 27;5:93. doi: 10.1186/1471-2334-5-93.
34. Schut ES, Lucas MJ, Brouwer MC, Vergouwen MD, van der Ende A, van de Beek D. Cerebral infarction in adults with bacterial meningitis. *Neurocrit Care*. 2012 Jun;16(3):421,427. doi: 10.1007/s12028-011-9634-4.
35. Worsøe L, Cayé-Thomasen P, Brandt CT, Thomsen J, Østergaard C. Factors associated with the occurrence of hearing loss after pneumococcal meningitis. *Clin Infect Dis*. 2010 Oct 15;51(8):917,924. doi: 10.1086/656409.
36. Canadian Institute for Health Information (CIHI). Data Quality Documentation, Discharge Abstract Database — Current-Year Information, 2015–2016 [Internet]. Ottawa (ON). 2016 [cited

2022 Jun 16]. Available from: <https://www.cihi.ca/sites/default/files/document/dad-data-quality-15-16-en.pdf>.

37. Canadian Institute for Health Information (CIHI). Data Quality Documentation, Discharge Abstract Database - Current-Year Information, 2016–2017 [Internet]. Ottawa (ON). 2017 [cited 2022 Jun 16]. Available from: <https://www.cihi.ca/sites/default/files/document/current-year-information-dad-2016-2017-en-web.pdf>.

38. Canadian Institute for Health Information (CIHI). Data Quality Documentation, Discharge Abstract Database - Current-Year Information, 2017–2018 [Internet]. Ottawa (ON). 2018 [cited 2022 Jun 16]. Available from: <https://www.cihi.ca/sites/default/files/document/current-year-information-dad-2017-2018-en-web.pdf>.

39. Canadian Institute for Health Information (CIHI). Data Quality Documentation Discharge Abstract Database - Current-Year Information 2018–2019 [Internet]. Ottawa (ON). 2019 [cited 2022 Jun 16]. Available from: <https://www.cihi.ca/sites/default/files/document/current-year-information-dad-2018-2019-en-web.pdf>.

40. Canadian Institute for Health Information (CIHI). Cost of a Standard Hospital Stay [Internet]. Ottawa (ON). [cited 2022 Mar 4]. Available from: <https://yourhealthsystem.cihi.ca/hsp/inbrief?lang=en#!/indicators/015/cost-of-a-standard-hospital-stay-cshs;/mapC1;mapLevel2;provinceC9001;/.>

41. Christensen H, Trotter CL, Hickman M, Edmunds WJ. Re-evaluating cost effectiveness of universal meningitis vaccination (Bexsero) in England: modelling study. *BMJ*. 2014 Oct 9;349:g5725. doi: 10.1136/bmj.g5725.

42. Kraicer-Melamed H, Baclic O, De Wals P, Quach C, Chevalier T, Moffatt C. An Advisory Committee Statement (ACS) National Advisory Committee on Immunization (NACI): Update on the use of pneumococcal vaccines in adults 65 years of age and older – A Public Health Perspective [Internet]. Ottawa (ON): Public Health Agency of Canada; 2018 Nov [cited 2022 Jun 16]. Available from: <https://www.canada.ca/en/public-health/services/publications/healthy-living/update-on-the-use-of-pneumococcal-vaccines-in-adult.html#a11>.

43. National Center for Immunization and Respiratory Diseases. CDC Vaccine Price List [Internet]. Atlanta (GA): Centers for Disease Control and Prevention; 2022 may 17 [cited 2022 Jun 16]. Available from: <https://www.cdc.gov/vaccines/programs/vfc/awardees/vaccine-management/price-list/index.html>.

44. Alberta PROMs & EQ-5D Research & Support Unit (APERSU). Alberta Population Norms for EQ-5D-5L [Internet]. Edmonton (AB): University of Alberta: School of Public Health; 2018 Sep 25 [cited 2022 Jun 16]. Available from: <https://apersu.ca/wp-content/uploads/2020/10/Alberta-Norms-Report-APERSU-1.pdf>.

45. Mangen MJ, Huijts SM, Bonten MJ, de Wit GA. The impact of community-acquired pneumonia on the health-related quality-of-life in elderly. *BMC Infect Dis*. 2017 Mar 14;17(1):208. doi: 10.1186/s12879-017-2302-3.

46. Oppong R, Jit M, Smith RD, Butler CC, Melbye H, Mölstad S, et al. Cost-effectiveness of point-of-care C-reactive protein testing to inform antibiotic prescribing decisions. *Br J Gen Pract*. 2013 Jul;63(612):e465,71. doi: 10.3399/bjgp13X669185.

47. Oppong R, Kaambwa B, Nuttall J, Hood K, Smith RD, Coast J. The impact of using different tariffs to value EQ-5D health state descriptions: an example from a study of acute cough/lower respiratory tract infections in seven countries. *Eur J Health Econ.* 2013 Apr;14(2):197,209. doi: 10.1007/s10198-011-0360-9.
48. Janssen MF, Szende A, Cabases J, Ramos-Goñi JM, Vilagut G, König HH. Population norms for the EQ-5D-3L: a cross-country analysis of population surveys for 20 countries. *Eur J Health Econ.* 2019 Mar;20(2):205,216. doi: 10.1007/s10198-018-0955-5.
49. Van Wilder L, Charafeddine R, Beutels P, Bruyndonckx R, Cleemput I, Demarest S, et al. Belgian population norms for the EQ-5D-5L, 2018. *Qual Life Res.* 2022 Feb;31(2):527,537. doi: 10.1007/s11136-021-02971-6.
50. Galante J, Augustovski F, Colantonio L, Bardach A, Caporale J, Marti SG, et al. Estimation and comparison of EQ-5D health states' utility weights for pneumococcal and human papillomavirus diseases in Argentina, Chile, and the United Kingdom. *Value Health.* 2011 Aug;14(5 Suppl 1):S60,4. doi: 10.1016/j.jval.2011.05.007.
51. Seasonal Influenza Vaccination Coverage Survey, Canada, 2020-2021. [Unpublished]. Ottawa (ON): Government of Canada; 2021.
52. Farrar JL, Kobayashi M, Childs L, Pilishvili T. 21. Systematic Review and Meta-Analysis of Pneumococcal Vaccine Effectiveness against Invasive Pneumococcal Disease among Adults. *Open Forum Infectious Diseases.* 2021 Dec 4;8(Suppl 1):S134,S135. <https://doi.org/10.1093/ofid/ofab466.223>.
53. Bonten MJ, Huijts SM, Bolkenbaas M, Webber C, Patterson S, Gault S, et al. Polysaccharide conjugate vaccine against pneumococcal pneumonia in adults. *N Engl J Med.* 2015 Mar 19;372(12):1114,1125. doi: 10.1056/NEJMoa1408544.
54. Childs L, Kobayashi M, Farrar JL, Pilishvili T. 13. The Efficacy and Effectiveness of Pneumococcal Vaccines against Pneumococcal Pneumonia among Adults: A Systematic Review and Meta-Analysis. *Open Forum Infectious Diseases.* 2021 Dec 4;8(Suppl 1):S130,S131. <https://doi.org/10.1093/ofid/ofab466.215>.
55. Lawrence H, Pick H, Baskaran V, Daniel P, Rodrigo C, Ashton D, et al. Effectiveness of the 23-valent pneumococcal polysaccharide vaccine against vaccine serotype pneumococcal pneumonia in adults: A case-control test-negative design study. *PLoS Med.* 2020 Oct 23;17(10):e1003326. doi: 10.1371/journal.pmed.1003326.
56. Canadian Institute for Health Information (CIHI). National Grouping System Categories Report, Canada 2004–2005 [Internet]. Ottawa (ON). 2007 Aug [cited 2022 Jun 16]. Available from: https://publications.gc.ca/collections/collection_2012/icis-cihi/H115-11-2005-eng.pdf.
57. Government of Alberta. Hospital Ambulatory Care Case Costs - CACS - 2019 version [Internet]. Edmonton (AB). 2019 [cited 2022 Mar 4]. Available from: <http://www.ahw.gov.ab.ca/IHDA/Retrieval/selectSubCategoryParameters.do>.
58. Ministry of Health. Schedule of Benefits: Physician Services Under the Health Insurance Act [Internet]. Toronto (ON): Government of Ontario; 2022 Jan 24 [cited 2022 Jun 16]. Available from: https://health.gov.on.ca/en/pro/programs/ohip/sob/physerv/sob_master.pdf.

59. Yan S, Weycker D, Sokolowski S. US healthcare costs attributable to type A and type B influenza. *Hum Vaccin Immunother.* 2017 Sep 2;13(9):2041,2047. doi: 10.1080/21645515.2017.1345400.
60. Drug Programs Policy and Strategy Branch OHIP, Pharmaceuticals and Devices Division Ministry of Health. Ontario Drug Benefit: Formulary/Comparative Drug Index, Edition 43 [Internet]. Toronto (ON): Government of Ontario; 2022 Mar 31 [cited 2022 Jun 16]. Available from: https://health.gov.on.ca/en/pro/programs/drugs/formulary43/edition_43.pdf.
61. Glauser W, Pendharkar S, Nolan M. Why do you have to pay for an ambulance? [Internet]. Toronto (ON): Healthy Debate; 2015 Jul 30 [cited 2022 Jun 16]. Available from: <https://healthydebate.ca/2015/07/topic/ambulance-fees/>.
62. Government of Northwest Territories. Visitors to the NWT: EMERGENCY MEDICAL TRAVEL [Internet]. Yellowknife (NT). 2018 Jun [cited 2022 Jun 16]. Available from: <https://www.hss.gov.nt.ca/sites/hss/files/resources/visitors-emergency-medical-travel.pdf>.
63. The Government of Nunavut. Medical Travel - Medevac [Internet]. Iqaluit (NU). [cited 2022 May 11]. Available from: <https://www.gov.nu.ca/health/information/medical-travel-medevac>.
64. Rendell M. City Brief: Should City Reduce Ambulance Fees?: Council to consider whether \$225 for YK residents is too high [Internet]. Yellowknife (NT): EDGE Insider's Guide to Yellowknife; 2016 Mar 22 [cited 2022 Jun 16]. Available from: <https://edgenorth.ca/article/city-brief-should-city-reduce-ambulance-fees>.
65. Tam DY, Banerji A, Paes BA, Hui C, Tarride JE, Lanctôt KL. The cost effectiveness of palivizumab in term Inuit infants in the Eastern Canadian Arctic. *J Med Econ.* 2009;12(4):361,370. doi: 10.3111/13696990903442155.
66. Canada Revenue Agency. Reasonable per-kilometre allowance [Internet]. Ottawa (ON). 2022 Jan 3 [cited 2022 Jun 16]. Available from: <https://www.canada.ca/en/revenue-agency/services/tax/businesses/topics/payroll/benefits-allowances/automobile/automobile-motor-vehicle-allowances/reasonable-kilometre-allowance.html>.
67. Colbert Y. 'My jaw dropped,' says Ontario woman of \$12K air ambulance bill in Nova Scotia [Internet]. Ottawa (ON): CBC Radio-Canada; 2020 Nov 27 [cited 2022 Jun 16]. Available from: <https://www.cbc.ca/news/canada/nova-scotia/ground-and-air-ambulance-fees-health-care-universal-health-care-1.5817284>.
68. Government of Prince Edward Island. Ambulance Services [Internet]. Charlottetown (PEI). 2021 Apr 23 [cited 2022 May 11]. Available from: https://www.princeedwardisland.ca/en/information/health-and-wellness/ambulance-services?utm_source=redirect&utm_medium=url&utm_campaign=ambulance-services.
69. Government of Saskatchewan. Ambulance Services [Internet]. Regina (SK). [cited 2022 May 11]. Available from: <https://www.saskatchewan.ca/residents/health/emergency-medical-services/ambulance-services>.
70. Pong RW, Pitblado JR. Geographic distribution of physicians in Canada: beyond how many and where [Internet]. Ottawa (ON): Canadian Institute for Health Information; 2005 [cited 2022 Jun 16]. Available from: https://secure.cihi.ca/free_products/Geographic_Distribution_of_Physicians_FINAL_e.pdf.

71. Government of Yukon. Find out which medical travel costs our health plan covers [Internet]. Whitehorse (YT). [cited 2022 May 11]. Available from: <https://yukon.ca/en/medical-treatment-travel>.
72. Pasquale CB, Vietri J, Choate R, McDaniel A, Sato R, Ford KD, et al. Patient-Reported Consequences of Community-Acquired Pneumonia in Patients with Chronic Obstructive Pulmonary Disease. *Chronic Obstr Pulm Dis*. 2019 Apr 9;6(2):132,144. doi: 10.15326/jcopdf.6.2.2018.0144.
73. Income of individuals by age group, sex and income source, Canada, provinces and selected census metropolitan areas - Table: 11-10-0239-01 (formerly CANSIM 206-0052) [Internet]. Ottawa (ON): Statistics Canada; 2022 Mar 23 [cited 2022 Jun 16]. Available from: <https://www150.statcan.gc.ca/t1/tbl1/en/tv.action?pid=1110023901>.
74. Bizier C, Contreras R, Walpole A. Hearing disabilities among Canadians aged 15 years and older, 2012 - ARCHIVED [Internet]. Ottawa (ON): Statistics Canada; 2022 Jun 20 [cited 2022 Jun 16]. Available from: <https://www150.statcan.gc.ca/n1/en/catalogue/89-654-X2016002>.
75. Hollander MJ, Liu G, Chappell NL. Who Cares and How Much? The Imputed Economic Contribution to the Canadian Healthcare System of Middle-Aged and Older Unpaid Caregivers Providing Care to The Elderly [Internet]. Toronto (ON): Longwoods; 2009 Apr [cited 2022 Jun 16]. Available from: <https://www.longwoods.com/content/20660/healthcare-quarterly/who-cares-and-how-much-the-imputed-economic-contribution-to-the-canadian-healthcare-system-of-middl>.
76. Wyrwich KW, Yu H, Sato R, Powers JH. Observational longitudinal study of symptom burden and time for recovery from community-acquired pneumonia reported by older adults surveyed nationwide using the CAP Burden of Illness Questionnaire. *Patient Relat Outcome Meas*. 2015 Jul 30;6:215,223. doi: 10.2147/PROM.S85779.
77. Ganapathy V, Graham GD, DiBonaventura MD, Gillard PJ, Goren A, Zorowitz RD. Caregiver burden, productivity loss, and indirect costs associated with caring for patients with poststroke spasticity. *Clin Interv Aging*. 2015 Nov 6;10:1793,1802. doi: 10.2147/CIA.S91123.
78. Mt-Isa S, Abderhalden LA, Musey L, Weiss T. Matching-adjusted indirect comparison of pneumococcal vaccines V114 and PCV20. *Expert Rev Vaccines*. 2022 Jan;21(1):115,123. doi: 10.1080/14760584.2021.1994858.
79. Ren S, Newby D, Li SC, Walkom E, Miller P, Hure A, et al. Effect of the adult pneumococcal polysaccharide vaccine on cardiovascular disease: a systematic review and meta-analysis. *Open Heart*. 2015 Jun 26;2(1):e000247. doi: 10.1136/openhrt-2015-000247.
80. Marra F, Zhang A, Gillman E, Bessai K, Parhar K, Vadlamudi NK. The protective effect of pneumococcal vaccination on cardiovascular disease in adults: A systematic review and meta-analysis. *Int J Infect Dis*. 2020 Oct;99:204,213. doi: 10.1016/j.ijid.2020.07.038.